

# Implementation smart charging technique using particle swarm optimization to achieve best performance charger

Indhana Sudiharto, Farid Dwi Murdianto, Lavia Isnani

Department of Electrical Engineering, Politeknik Elektronika Negeri Surabaya, Surabaya, Indonesia

---

## Article Info

### Article history:

Received Dec 14, 2022

Revised Mar 7, 2023

Accepted Mar 31, 2023

---

### Keywords:

Battery  
Charging  
Portable electronic device  
PSO  
Smart charger

---

## ABSTRACT

These days, there are an increasing number of electronic devices that use batteries as their energy source, often known as portable electronic devices. However, the battery may run out of energy and a recharging process is required to keep the electronic device functional. A charger that is in accordance with the battery specifications is required to complete the charging process. Incompatible chargers can overcharge batteries and shorten their lifetime. Since there are many different types of electronic devices, many different chargers are required, especially since most chargers on the market are static and can only be used with one kind of electronic device. This will increase the costs that customers must pay, especially those who have many types of electronic devices. As a result, this research will create a smart charger using the PSO algorithm that can be used to complete the charging process on all types of portable electronic devices. To test smart chargers, five different battery types from electronic devices with different specifications are used. From the test result, the smart charger can charge five different types of battery loads with various specifications with 100% accuracy at a speed that takes 50.4 seconds to reach a steady state.

*This is an open access article under the [CC BY-SA](https://creativecommons.org/licenses/by-sa/4.0/) license.*

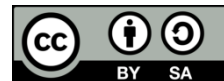

---

## Corresponding Author:

Indhana Sudiharto

Department of Electrical Engineering, Politeknik Elektronika Negeri Surabaya

Raya ITS St.- PENS Campus Sukolilo, Surabaya, 60111, Indonesia

Email: indhana@pens.ac.id

---

## 1. INTRODUCTION

The advancement of technology provides many advantages for humans, especially in terms of making work easier. One of these technological advancements is the increase of the variety of DC electronic devices that are already in use today. DC electronic devices, often known as portable electronic devices, are inseparable from human life and are widely used as personal to high-tech devices [1]. Because portable electronic devices have their own power source, a battery, they can be utilized anywhere and anytime. The battery's energy source is created when chemical energy is converted into electrical energy [2]. However, the energy in the battery can run out and to continue using the portable electronic device when the energy in the battery runs out, a charging process is required [3].

A charger that is appropriate to the battery's specifications must be used during the recharging process because an inappropriate charger could cause overcharging and damage to the battery [4], [5]. Unfortunately, the most of chargers that are now available on the market are static, means that each charger is only compatible with a specific kind of electronic device [5]. If you have a variety of DC electronic devices, it will require a lot of charges. This will increase the costs that customers must pay and seem inefficient.

These problems can be solved by using a charger that is adaptable and flexible so that it can adjust to match the requirements of the connected battery load. This kind of charger will be able to prevent

overcharging during the charging process. Additionally, the requirement for a large number of chargers can be reduced when using DC electronic devices with various battery specifications. With a smart charger, various type of DC electrical devices can be recharged with just one charger. This becomes more efficient, especially for travelers who bring along many DC electrical devices, including as handphone, headlamp, camera, laptop, and other devices. Additionally, this charger might lower the costs that consumers must pay.

A voltage regulator is required so that the output voltage can adjust in accordance with the connected load [6]. One of the many voltage regulators available is the DC-DC Converter. The duty cycle value that enters the switching component of the DC-DC Converter can be adjusted to change the output voltage value. A buck converter is one of the many types of DC-DC converters. By modifying the duty cycle value, it can reduce the voltage from a higher voltage to a lower voltage [7], [8]. The smart charger must be able to detect the load, identify the connected load type, produce an output value that matches to the load, and be able to maintain output stability in order to finish the charging process correctly [9]. To do this, a more complex special method that can carry out the load identification process more accurately is required [10].

In this study, a smart charger that can identify loads was created using the particle swarm optimization (PSO) algorithm, which represents the social behavior of a swarm of fish or birds looking for food [11], [12]. PSO will work to find the best solution while randomly assigning the particle's initial position [13]. The duty cycle value, which controls the buck converter's output voltage in the smart charger system, is used to implement the PSO algorithm's particles. The PSO algorithm will initially distribute the duty cycle value in order to quickly and accurately identify the connected load type. After the setpoint value required by the load is known, the PSO algorithm will continue looking for a solution by determining the duty cycle value that is most optimal given the setpoint value that the load requires. The optimal duty cycle in this issue is the duty cycle that allows the converter to produce its output voltage in accordance with the setpoint that the load requires. The optimal duty cycle value will be found, and this value will be kept constant to ensure that the buck converter's output is consistent and recharging works at a constant voltage. The method will prevent overcharging caused on the charging voltage that exceeds the load specifications [14], [15].

From all of the references mentioned, a smart charger system using a buck converter and the PSO algorithm was created for this research. This smart charger system can identify loads more quickly and correctly by using the PSO algorithm, and it can also adjust the buck converter to produce a consistent output according to the load requirements. In this research, five different battery loads with slightly different charging voltages were used to test the smart charger. The batteries include mosquito racket battery (2.8 V), headlamp (4.2 V), handphone (5 V), RC car battery (7.2 V), and camera battery (8.4 V).

## 2. RESEARCH METHOD

In this research, a smart charger system that can be used to recharge various battery types in portable electronic devices with various specifications will be created. Figure 1 shows the diagram of the blog system. Figure 1 explains the smart charger's process from the input side to the load at the output. The source used is a 12 V DC supply, which then enters the buck converter. The duty cycle value that is set using the PSO algorithm will determine the buck converter's output voltage. A current sensor and a voltage sensor are located at the buck converter's output and are used to monitor the current and voltage at the converter's output. In order to get the optimal duty cycle value, Particle Swarm Optimization will use the buck converter output current and voltage as reference values. On the other hand, the output side has a single output port that can be alternately used for a variety of loads. The load used in this research included five various types of batteries from portable DC electronic devices, each with various specifications and a charging voltage that was close to the value of each battery. These loads include mosquito racket battery, headlamp, handphone, RC car battery, and camera battery.

Based on Figure 2, the smart charger process using the PSO algorithm entails detecting the presence of a load, determining the type of load, determining the setpoint value on the load, and charging the load with the appropriate charging voltage. The load detection process is used to determine if there is a connected load. A limit switch is used in this process as an indicator, when a load is connected, the limit switch will have a value of one, indicating that the system is on. The limit switch will be at zero when the load is disconnected or when there is no load connected to the output port, and the system will turn off automatically. This system has five load clusters: load cluster 1 is for mosquito racket battery, load cluster 2 is for headlamp, load cluster 3 is for handphone, load cluster 4 is for RC car battery, and load cluster 5 is for camera battery. After that, the PSO algorithm is used to carry out the identification process, spreading the initialization duty cycle values sequentially from cluster 1 to cluster 5. After then, it will be checked to see if there is a legible current value, which is assumed to be  $I_o \geq 0.1$  A. The load can be identified if the read current value is more than 0.1 A, but if it is not, identification continues to the next load cluster and so on. When the load has been identified, the load's setpoint value can be determined using the load cluster. After that, the PSO algorithm

will continue looking for solutions to find the optimal duty cycle value and allow the buck converter to output a signal that is in accordance with the setpoint. In order to maintain a steady voltage during the charging process, this value will be maintained constant.

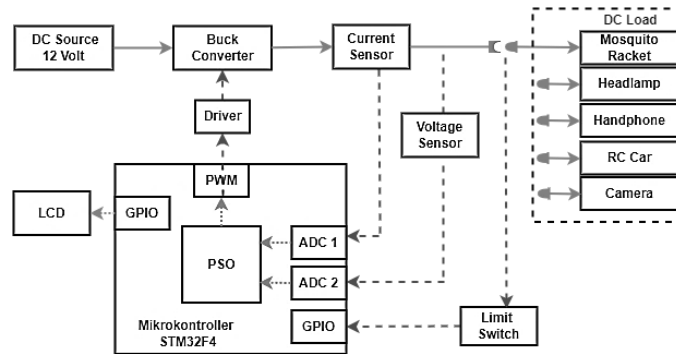

Figure 1. Overall system of smart charger

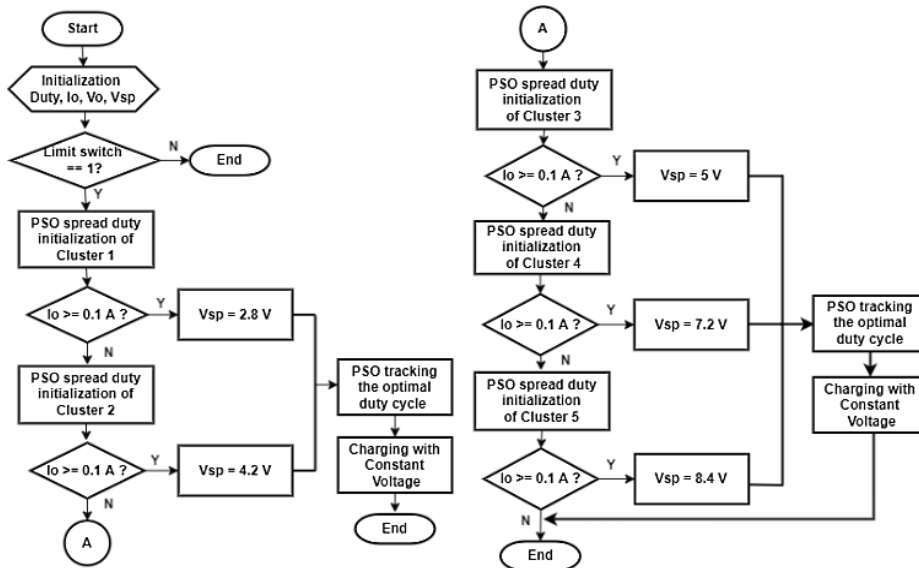

Figure 2. Flowchart system of smart charger

**2.1. Buck converter modeling**

In the industry, buck converter is a common type of DC-DC converter used to reduce the input voltage to a lower output voltage [16], [17]. The buck converter works as a step-down converter in the smart charger system to ensure that the output voltage value is in accordance with the load specifications. Figure 3 shows the topology of the buck converter.

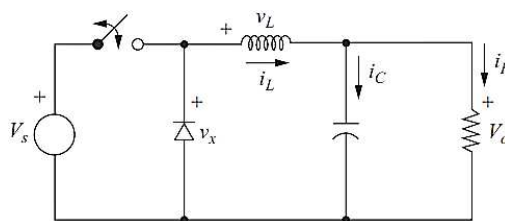

Figure 3. Topology of buck converter [6]

There are two sections in the buck converter: a power part for converting voltage and a control section for turning the switch ON and OFF [18]. The switch is closed and the diode is reverse biased when the buck converter is in the ON state, as shown in Figure 4(a), allowing the inductor and capacitor to be connected to a voltage source. The switch is opened and the diode is forward biased when the buck converter is in the OFF state shown in Figure 4(b), isolating all of its components from the voltage source [19]. The equations below can be used to search through a number of parameters in the buck converter [6].

$$V_o = V_s \times D \tag{1}$$

$$L = \frac{1}{f} \times (V_{s(max)} - V_o) \times \left[ \frac{V_o + V_f}{V_{s(max)} + V_f} \right] \times \frac{1}{\Delta i_L} \tag{2}$$

$$C = \frac{(1-D) \times V_o}{8 L f^2 \Delta V_o} \tag{3}$$

Where  $V_o$ : output voltage,  $V_{in}$ : input voltage,  $D$ : duty cycle,  $L$ : inductor,  $f$ : frequency,  $V_f$ : forward voltage,  $C$ : capacitor,  $\Delta i_L$ : ripple current, and  $\Delta V_o$ : ripple voltage.

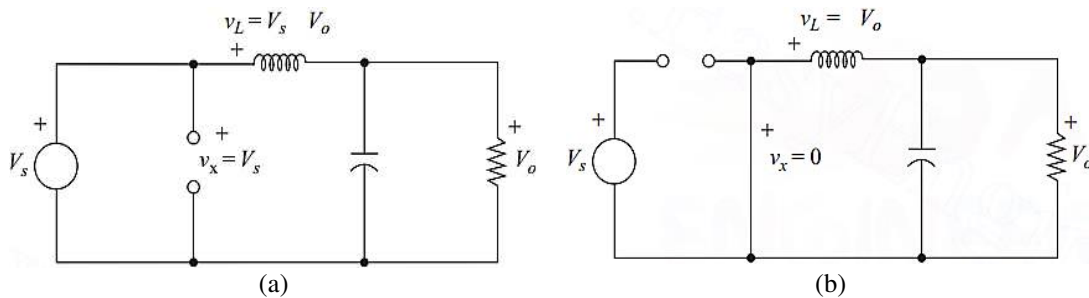

Figure 4. Equivalent circuit for the state (a) ON and (b) OFF [6]

In designing a buck converter, several parameter calculations are needed to calculate precisely because the parameters used can affect the output of the converter. Table 1 shows the parameters for the buck converter. A buck converter is created using these parameters, and its output is then tested using open loop testing. The duty cycle value was adjusted to produce output voltages of 2.8 V, 4.2 V, 5 V, 7.2 V, and 8.4 V during the testing of the buck converter utilizing five different load variations. These voltages' respective duty cycle values are 0.234, 0.35, 0.416, 0.6, and 0.7. Figure 5 shows the documentation for the open loop buck converter test.

Table 1. Parameter of buck converter

Parameter	Value
Input voltage ( $V_{in}$ )	12 Volt
Output voltage ( $V_o$ )	8.4 Volt
Ripple current ( $\Delta i_L$ )	20 %
Ripple voltage ( $\Delta V_o$ )	0.01 %
Frequency switching ( $f_s$ )	40 kHz
Inductor ( $L$ )	165 $\mu$ H
Capacitor ( $C$ )	2 nF

The documentation of buck converter testing that was done in an open loop is shown in Figure 5. The buck converter output is connected to 5 different types of loads for the test, and the duty cycle value is adjusted in accordance with the calculations of each load. Duty cycles of 0.234 for mosquito racket load, 0.35 for headlamp load, 0.416 for handphone load, 0.6 for RC car load, and 0.7 for camera load were used during testing. According to test results in steady state settings, the output value produced significantly differs from the target setpoint. The test results are shown in Table 2 for more details.

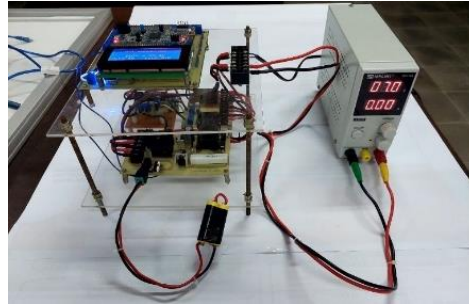

Figure 5. Open loop testing of buck converter

Table 2 shows the results of the open loop buck converter test, where the five duty cycle values are varied according to the load. Based on the data, it can be seen that the average error value is a rather high 5.25%, and the greatest error value is 8.81%. As a result, control is required for the smart charger system to be created to produce the correct buck converter output as the load charging voltage.

Table 2. Buck converter test result data

No	Load	Duty cycle (%)	Vo Theory (V)	Vo Testing (Vo)	Error (%)
1	Mosquito racket	23.4	2.8	2.74	2.14
2	Headlamp	35	4.2	3.91	6.91
3	Handphone	41.7	5	4.67	6.60
4	RC car	60	7.2	7.07	1.81
5	Camera	70	8.4	7.66	8.81
Average error					5.25

## 2.2. Basic of PSO

Particle swarm optimization is an optimization method inspired by the social behavior of a group of animals. Kennedy and Eberhart first proposed this method in 1995 [20]. By imitating the social behavior of flocks of birds or schools of fish in search of food, particle swarm optimization can be utilized to find solutions [21]. The PSO algorithm's solution is found by randomly selecting candidates from a population. Every population contains individuals or particles that have the potential to influence other particles, and every particle has two properties: position and velocity [22]. Each of these particles will move in a specific area and then, by continuously updating its position, determine the best position through which it should pass. In order for the other particles to change their location and speed based on the best position information they have received, each particle will transmit the best position information to the other particles [23]. Each particle position can be represented by the symbol  $x_i$ , which refers to a point in a particular space-time dimension. While each particle updates its position at a speed known as velocity ( $\phi_i$ ).

Figure 6 shows how the PSO algorithm works to identify the optimal solution by adjusting the particle positions [24]. The particle will move from its initial position, which is assumed to be  $x_i^{k-1}$ , to its next position, which is  $x_i^k$ . Iteration is symbolized by the  $k$  sign. The particle's movement from the first position to the second position will be influenced by the initial velocity value, which is assumed to be  $\phi_i^k$ . Similarly, the particle's position will change from its initial  $x_i^k$  position to its final  $x_i^{k+1}$  position depending on its velocity  $\phi_i^{k+1}$ . Particle  $x_i$  will continue to move positions until it achieves the position that is both  $Pbest_i$  which represents for the best value for each particle and  $Gbest_i$  which represents for the best value in one population. The PSO will reach to a convergent condition and maintain the  $Gbest$  value when the  $Gbest$  value has been achieved. In the solution search process, a number of parameters, including inertia weight ( $w$ ), learning factor ( $c_1$  and  $c_2$ ), and random variables ( $r_1$  and  $r_2$ ) with values between 0 and 1, affect the velocity value of each moving particle position [25]. The particle swarm optimization method's equation is as follows [26]:

$$v_i^{k+1} = w \cdot v_i^k + c_1 \cdot r_1 (Pbest_i - x_i^k) + c_2 \cdot r_2 (Gbest_i - x_i^k) \quad (4)$$

$$x_i^{k+1} = x_i^k + v_i^{k+1} \quad (5)$$

Where  $x_i$ : particle position  $i$ ,  $v_i$ : particle velocity  $i$ ,  $k$ : number of iterations,  $w$ : moment inertia,  $c_1$  and  $c_2$ : learning factor,  $r_1$  and  $r_2$ : random variable,  $Pbest_i$ : the best value of particle  $i$ , and  $Gbest_i$ : the best value of population.

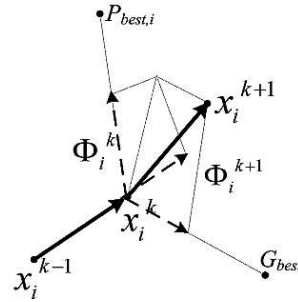

Figure 6. Particle moving for optimizing process [24]

### 2.3. PSO for adaptive charger system

The particle swarm optimization algorithm is used in the smart charger system to identify the load, determine the setpoint value for each connected load, and maintain a consistent charging voltage during the charging process. The duty cycle value that enters the buck converter determines the particles in the smart charger system, and this value also affects the system's output voltage value. The steps of the charging process on the smart charger system using the PSO algorithm are explained below.

#### 2.3.1. Duty cycle clustering

In this research, five batteries from portable electronic devices with varying capacitance and charging voltage served as the load. To test the reliability of the system in identifying the load, a battery is used which has a charging voltage value with a small difference between one battery and another. Each load is placed in its own cluster. The duty cycle clustering, where each load cluster has a different voltage range, serves to ease the identification process. Given that the PSO algorithm searches for solutions at random, creating this loading cluster can also lower the chance that the load will suffer a charging voltage during identification that is more than the load's capacity. Data for each load and duty cycle clustering can be seen in Table 3. Table 3 shows that there are five duty cycle clustering consisting of five different types of battery loads with varying charging rates. The initial duty cycle value is also set in the 5 loading clusters, and the PSO algorithm will spread it later to identify the load.

Table 3. Duty cycle clustering

Cluster	Load	Setting point	Duty cycle clustering
1	Mosquito racket	2.8 V	0.05–0.3
2	Headlamp	4.2 V	0.05–0.4
3	Handphone	5 V	0.05–0.5
4	RC car	7.2 V	0.05–0.6
5	Camera	8.4 V	0.05–0.7

#### 2.3.2. Load identification

The PSO algorithm spread the initial particle positions randomly during the process of identifying the load on the smart charger system, as long as they remain within each cluster's duty cycle range. From the first cluster to the fifth cluster, the identification process will be carried out in a sequential. The process of load identification is continued by monitoring the buck converter output current value after the first cluster duty cycle value has been distributed. The battery current will only appear during the charging process when the charging voltage supplied exceeds the nominal voltage of the battery, so the current value can be used as a reference in the process of determining the type of load that is connected. The identifying current in this research is considered to be 0.1 A. When the output current  $I_o \geq 0.1$  A and the duty cycle of the first cluster is spread, it can be assumed that the connected load is the load on the first cluster. But if no current is read, the PSO algorithm will spread the duty cycle value in the second cluster and so on until the load can be identified. Using the PSO algorithm speeds up the identification process since it may spread the duty cycle randomly. This will be more effective when the load used is more and more variations.

#### 2.3.3. Searching the optimal duty cycle

When the load has been accurately identified, the system can use the load cluster to determine the setpoint voltage value that matches with the load. In order to determine the optimal duty cycle value, the PSO algorithm will keep moving the particle position. The optimal duty cycle value is the duty cycle value that

can provide a system output voltage in accordance with the setpoint value. The PSO will search for a duty cycle value that can produce a converter output voltage of 2.8 V when the connected load is a mosquito racket battery load, 4.2 V for headlamp load, 5 V for handphone load, 7.2 V for RC car battery load, and 8.4 V for camera battery load.

The (4) and (5) are used to update the speed value and duty cycle position, respectively. Until the optimal duty cycle value ( $G_{best}$ ) is found and the algorithm finally reaches a convergence condition, the speed value in the PSO algorithm will gradually drop. When the convergence condition is met, the duty cycle value will be constant and enter the buck converter. The charging process will proceed at a constant voltage because the buck converter will likewise create a constant output. The PSO algorithm on the smart charger system in this research used the following values for each parameter: i) Weight ( $w$ ) = 0.5; ii)  $C1 = 0.8$ ; iii)  $C2 = 0.8$ ; and iv) The initial/initialization duty cycle corresponds to the loading cluster.

### 3. RESULTS AND DISCUSSION

The results of the smart charging system's implementation will be presented in this section. Five different loads with various specifications and various charging voltage values were used to test smart charger hardware using the PSO algorithm. Among some of the loads used are batteries for mosquito racket, which have a setpoint of 2.8 V, headlamp, which have a setpoint of 3.2 V, handphone, which have a setpoint of 5 V, RC car battery, which have a setpoint of 7.2 V, and a camera battery, which has a setpoint of 8.4 V.

The initial condition of the system is no load, where the system will not detect a load and the system will stay off. When a load is connected, the limit switch will depress and turning the system on. The identification process is then carried out by sequentially applying the PSO algorithm to each cluster's initialization duty cycle value from the first cluster to the fifth cluster. The voltage value and the first current value that appear in a certain cluster are the parameters used in the load identification process so that it is possible to determine which load is currently connected, including which cluster. When identified, the setpoint value required by the load can be determined. The PSO algorithm will then keep monitoring the duty cycle until it finds an optimal duty cycle value that produces an output voltage value equal to the setpoint value. The duty cycle value will be changed repeatedly until the charging process is finished in order to maintain this output voltage value.

In the smart charger hardware, there are several values that can be seen to monitor the charging process on the battery load. There are duty cycle values, voltage values, current values, and power values. The values of the current, and power will always change depending on the charging process at the battery load. Meanwhile, the duty cycle value and voltage value that initially change will be constant when the voltage value is in accordance with the setpoint. The documentation used to test the smart charger hardware using a battery load from a mosquito racket is shown in Figure 7. The battery used in the mosquito racket has a capacity of 2.4 V/700 mAh and a charging voltage of 2.8 V. The system output was then connected to the battery connector on the mosquito racket for the test.

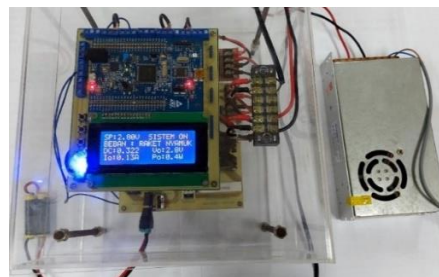

Figure 7. System implementation for charging mosquito racket battery

To know that the charging process can run well, test data is collected using RS communication, and the data is presented using a graph. Figure 8 is a graph that represents the data retrieved from 240-second closed-loop hardware integration testing on a battery load for a mosquito racket. The graph shows that the voltage value fluctuates in the initial condition, indicating that the PSO algorithm is still identifying the load and attempting to determine the optimal duty cycle value. When the optimal duty cycle is found, the system's output voltage value will equal the setpoint value, where the needed output voltage value for the load in the form of a mosquito racket battery is 2.8 V. In testing using a mosquito racket battery load, it was seen that the

optimal duty cycle value was found at 18 seconds. This can be seen from the graph in Figure 8, where the system reaches a steady state with an output voltage value of 2.8 V in the 18th second. The system will continue the charging process at a constant voltage until the charging process is complete. The documentation used to test the smart charger hardware using a battery load from a headlamp is shown in Figure 9. The battery used in the headlamp has a capacity of 3.7 V/2200 mAh and a charging voltage of 4.2 V. The system output was then connected to the battery connector on the headlamp for a test.

To know that the charging process can run well, test data is collected using RS communication, and the data is presented using a graph. Figure 10 is a graph that represents the data retrieved from 240-second closed-loop hardware integration testing on a battery load for a headlamp. The graph shows that the voltage value fluctuates in the initial condition, indicating that the PSO algorithm is still identifying the load and attempting to determine the optimal duty cycle value. When the optimal duty cycle is found, the system's output voltage value will equal the setpoint value, where the needed output voltage value for the load in the form of a headlamp is 4.2 V. In testing using a headlamp battery load, it was seen that the optimal duty cycle value was found at 44 seconds. This can be seen from the graph in Figure 10, where the system reaches a steady state with an output voltage value of 4.2 V in the 44th second. The system will continue the charging process at a constant voltage until the charging process is complete. The documentation used to test the smart charger hardware using a battery load from a handphone is shown in Figure 11. The battery used in the handphone has a capacity of 3.8 V/2000 mAh and a charging voltage of 5 V. The system output was then connected to the battery connector on the handphone for the test.

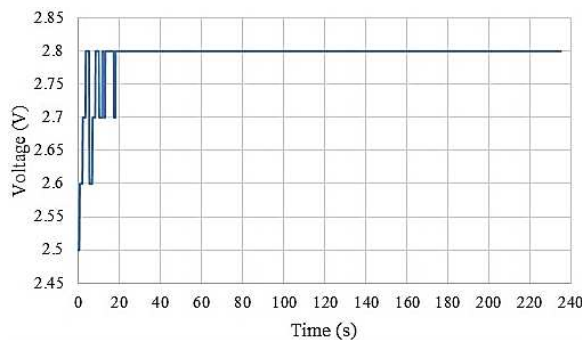

Figure 8. Graph of charging mosquito racket battery



Figure 9. System implementation for charging headlamp

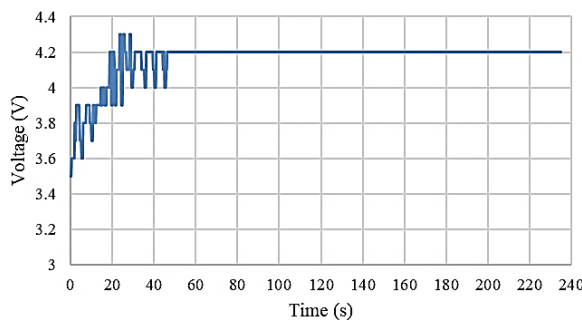

Figure 10. Graph of charging headlamp

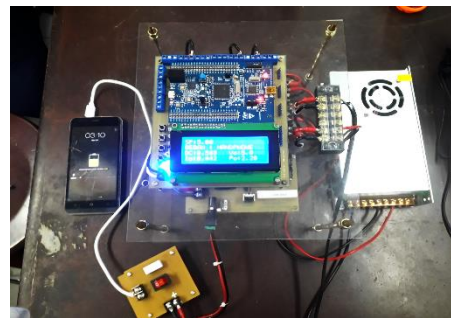

Figure 11. System implementation for charging handphone

To know that the charging process can run well, test data is collected using RS communication, and the data is presented using a graph. Figure 12 is a graph that represents the data retrieved from 240-second closed-loop hardware integration testing on a battery load for a handphone. The graph shows that the voltage value fluctuates in the initial condition, indicating that the PSO algorithm is still identifying the load and attempting to determine the optimal duty cycle value. When the optimal duty cycle is found, the system's output voltage value will equal the setpoint value, where the needed output voltage value for the load in the form of a handphone is 5 V. In testing using a handphone as a load, it was seen that the optimal duty cycle value was found at 90 seconds. This can be seen from the graph in Figure 12, where the system reaches a steady state with an output voltage value of 5 V in the 90th second. The system will continue the charging

process at a constant voltage until the charging process is complete. The documentation used to test the smart charger hardware using a battery load from an RC car battery is shown in Figure 13. The battery used in the RC car has a capacity of 6 V/2200 mAh and a charging voltage of 7.2 V. The system output was then connected to the battery connector on the RC car battery for the test.

To know that the charging process can run well, test data is collected using RS communication, and the data is presented using a graph. Figure 14 is a graph that represents the data retrieved from 240-second closed-loop hardware integration testing on a battery load for an RC car battery. The graph shows that the voltage value fluctuates in the initial condition, indicating that the PSO algorithm is still identifying the load and attempting to determine the optimal duty cycle value. When the optimal duty cycle is found, the system's output voltage value will equal the setpoint value, where the needed output voltage value for the load in the form of a RC car battery is 7.2 V. In testing using a RC car battery as a load, it was seen that the optimal duty cycle value was found at 52 seconds. This can be seen from the graph in Figure 14, where the system reaches a steady state with an output voltage value of 7.2 V in the 52th second. The system will continue the charging process at a constant voltage until the charging process is complete. The documentation used to test the smart charger hardware using a battery load from a camera is shown in Figure 15. The battery used in the camera has a capacity of 7.2 V/1120 mAh and a charging voltage of 8.4 V. The system output was then connected to the battery connector on the camera for the test.

To know that the charging process can run well, test data is collected using RS communication, and the data is presented using a graph. Figure 16 is a graph that represents the data retrieved from 240-second closed-loop hardware integration testing on a battery load for a camera. The graph shows that the voltage value fluctuates in the initial condition, indicating that the PSO algorithm is still identifying the load and attempting to determine the optimal duty cycle value. When the optimal duty cycle is found, the system's output voltage value will equal the setpoint value, where the needed output voltage value for the load in the form of a camera battery is 8.4 V. In testing using a camera battery load, it was seen that the optimal duty cycle value was found at 48 seconds. This can be seen from the graph in Figure 16, where the system reaches a steady state with an output voltage value of 8.4 V in the 48th second. The system will continue the charging process at a constant voltage until the charging process is complete.

Table 4 shows that the smart charger system is working successfully, as shown by the system's ability to correctly identify the connected load and supply the appropriate charging voltage value. The smart charger test results show that the system can correctly give an output that matches the setpoint without any errors, although each load takes a varied period of time to reach steady state conditions.

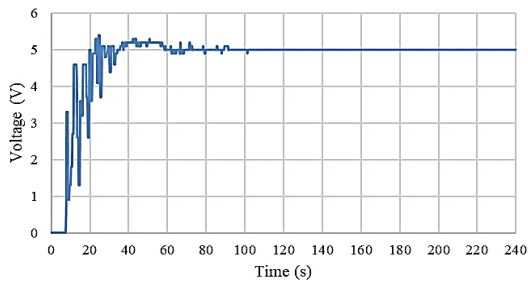

Figure 12. Graph of charging handphone

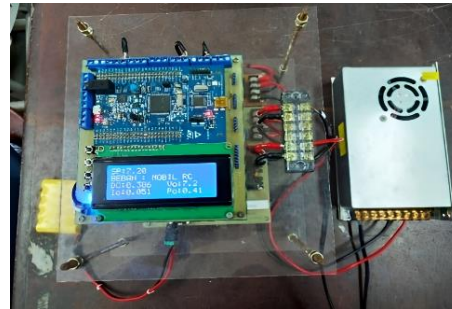

Figure 13. System implementation for charging RC car battery

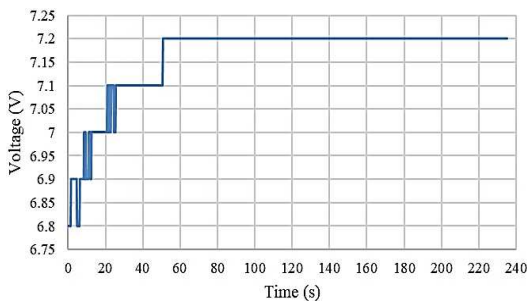

Figure 14. Graph of charging RC car battery



Figure 15. System implementation for charging camera battery

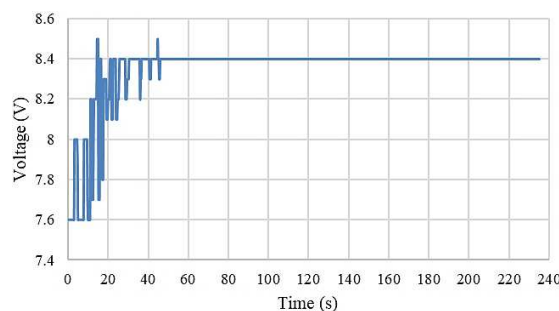

Figure 16. Graph of charging camera battery

Table 4. The result of output voltage response

Load	Setting Point (V)	Vout Testing (V)	Steady State Time (s)	Error (%)
Mosquito racket	2.8	2.8	18	0
Headlamp	4.2	4.2	44	0
Handphone	5	5.0	90	0
RC car	7.2	7.2	52	0
Camera	8.4	8.4	48	0
Average steady state time and error			50.4	0

#### 4. CONCLUSION

Based on the results of the tests that have been carried out, it can be seen that the smart charger system using the PSO algorithm can run well. The reliability of the smart charger system was tested using five kinds of battery loads from portable electronic devices that have different capacities. From the results of the tests, it can be concluded that the system can carry out the load detection process, identify the type of connected load, determine the setpoint value that matches the connected load and can maintain output stability during the charging process. The smart charger system produces an output voltage that is accurate and without any error values. Meanwhile, it takes just 50.4 seconds for the smart charger system to reach a steady state condition at the setpoint value.



#### REFERENCES

- [1] Y. Liang *et al.*, "A review of rechargeable batteries for portable electronic devices," *InfoMat*, vol. 1, no. 1, pp. 6–32, Mar. 2019, doi: 10.1002/inf2.12000.
- [2] K. Schmidt-Rohr, "How batteries store and release energy: explaining basic electrochemistry," *Journal of Chemical Education*, vol. 95, no. 10, pp. 1801–1810, Oct. 2018, doi: 10.1021/acs.jchemed.8b00479.
- [3] N. Meena *et al.*, "Charging and discharging characteristics of Lead acid and Li-ion batteries," in *2014 Power and Energy Systems: Towards Sustainable Energy*, Mar. 2014, pp. 1–3, doi: 10.1109/PESTSE.2014.6805253.
- [4] A. N. Maulidyna, I. Sudiharto, and F. D. Murdianto, "Multi DC load single port output adaptive power charge using fuzzy logic controller," *IOP Conference Series: Materials Science and Engineering*, vol. 1096, no. 1, p. 012063, Mar. 2021, doi: 10.1088/1757-899X/1096/1/012063.
- [5] F. D. Murdianto, I. Sudiharto, I. Irianto, and A. Wulandari, "Adaptive power charge using PID controller on DC load application," *INTEK: Jurnal Penelitian*, vol. 7, no. 2, p. 138, Feb. 2021, doi: 10.31963/intek.v7i2.2652.
- [6] D. W. Hart, *Power electronics*. The McGraw-Hill Companies, Inc, 2010.
- [7] D. Guilbert, S. M. Collura, and A. Scipioni, "DC/DC converter topologies for electrolyzers: state-of-the-art and remaining key issues," *International Journal of Hydrogen Energy*, vol. 42, no. 38, pp. 23966–23985, Sep. 2017, doi: 10.1016/j.ijhydene.2017.07.174.
- [8] N. H. Baharudin, T. M. N. T. Mansur, F. A. Hamid, R. Ali, and M. I. Misrun, "Performance analysis of DC-DC buck converter for renewable energy application," *Journal of Physics: Conference Series*, vol. 1019, p. 012020, Jun. 2018, doi: 10.1088/1742-6596/1019/1/012020.
- [9] I. Sudiharto, F. D. Murdianto, and A. Wulandari, "Adaptive charging control using ANN-PID controllers on multiple DC loads with varying battery voltages," *International Journal of Power Electronics and Drive Systems (IJPEDS)*, vol. 13, no. 1, p. 620, Mar. 2022, doi: 10.11591/ijped.v13.i1.pp620-630.
- [10] X. Zhang, Y. Wang, C. Liu, and Z. Chen, "A novel approach of battery pack state of health estimation using artificial intelligence optimization algorithm," *Journal of Power Sources*, vol. 376, pp. 191–199, Feb. 2018, doi: 10.1016/j.jpowsour.2017.11.068.
- [11] D. Wang, D. Tan, and L. Liu, "Particle swarm optimization algorithm: an overview," *Soft Computing*, vol. 22, no. 2, pp. 387–408, Jan. 2018, doi: 10.1007/s00500-016-2474-6.
- [12] M. A. El-Shorbagy and A. E. Hassanien, "Particle swarm optimization from theory to applications," *International Journal of Rough Sets and Data Analysis*, vol. 5, no. 2, pp. 1–24, Apr. 2018, doi: 10.4018/IJRSDA.2018040101.
- [13] N. K. Jain, U. Nangia, and J. Jain, "A review of particle swarm optimization," *Journal of The Institution of Engineers (India): Series B*, vol. 99, no. 4, pp. 407–411, Aug. 2018, doi: 10.1007/s40031-018-0323-y.
- [14] E. Banguero, A. Correcher, Á. Pérez-Navarro, F. Morant, and A. Aristizabal, "A review on battery charging and discharging control strategies: application to renewable energy systems," *Energies*, vol. 11, no. 4, p. 1021, Apr. 2018, doi: 10.3390/en11041021.
- [15] L. Mohammad, E. Prasetyono, and F. D. Murdianto, "Performance evaluation of ACO-MPPT and constant voltage method for street lighting charging system," in *2019 International Seminar on Application for Technology of Information and*



- Communication (iSemantic)*, Sep. 2019, pp. 411–416, doi: 10.1109/ISEMANTIC.2019.8884303.
- [16] A. W. Cristri and R. F. Iskandar, “Analysis and design of dynamic buck converter with change in value of load impedance,” *Procedia Engineering*, vol. 170, pp. 398–403, 2017, doi: 10.1016/j.proeng.2017.03.064.
- [17] P. Alavi, E. Babaei, P. Mohseni, and V. Marzang, “Study and analysis of a DC–DC soft-switched buck converter,” *IET Power Electronics*, vol. 13, no. 7, pp. 1456–1465, May 2020, doi: 10.1049/iet-pel.2019.0431.
- [18] K. Swathy, S. Jantre, Y. Jadhav, S. M. Labde, and P. Kadam, “Design and hardware implementation of closed loop buck converter using fuzzy logic controller,” in *2018 Second International Conference on Electronics, Communication and Aerospace Technology (ICECA)*, Mar. 2018, pp. 175–180, doi: 10.1109/ICECA.2018.8474570.
- [19] E. Setiawan, T. Hirata, and I. Hodaka, “Accurate symbolic steady state modeling of buck converter,” *International Journal of Electrical and Computer Engineering (IJECE)*, vol. 7, no. 5, p. 2374, Oct. 2017, doi: 10.11591/ijece.v7i5.pp2374-2381.
- [20] J. C. Bansal, “Particle Swarm Optimization,” in *Evolutionary and Swarm Intelligence Algorithms*, J. C. Bansal, P. K. Singh, and N. R. Pal, Eds. 2019, pp. 11–23.
- [21] M. Hajihassani, D. Jahed Armaghani, and R. Kalatehjari, “Applications of particle swarm optimization in geotechnical engineering: a comprehensive review,” *Geotechnical and Geological Engineering*, vol. 36, no. 2, pp. 705–722, Apr. 2018, doi: 10.1007/s10706-017-0356-z.
- [22] B. Chopard and M. Tomassini, “Particle Swarm Optimization,” in *An Introduction to Metaheuristics for Optimization*, 2018, pp. 97–102.
- [23] F. Wang, H. Zhang, K. Li, Z. Lin, J. Yang, and X.-L. Shen, “A hybrid particle swarm optimization algorithm using adaptive learning strategy,” *Information Sciences*, vol. 436–437, pp. 162–177, Apr. 2018, doi: 10.1016/j.ins.2018.01.027.
- [24] K. Ishaque, Z. Salam, M. Amjad, and S. Mekhilef, “An improved particle swarm optimization (PSO)-based mppt for PV with reduced steady-state oscillation,” *IEEE Transactions on Power Electronics*, vol. 27, no. 8, pp. 3627–3638, Aug. 2012, doi: 10.1109/TPEL.2012.2185713.
- [25] W. Hayder, A. Abid, M. Ben Hamed, E. Oglari, and L. Sbita, “Comparison of MPPT methods FLC & PSO for PV system under variable irradiance and temperature,” in *2021 18th International Multi-Conference on Systems, Signals & Devices (SSD)*, Mar. 2021, pp. 1247–1251, doi: 10.1109/SSD52085.2021.9429346.
- [26] M. Balamurugan, S. Narendiran, S. K. Sahoo, R. Das, and A. K. Sahoo, “Application of particle swarm optimization for maximum power point tracking in PV system,” in *2016 3rd International Conference on Electrical Energy Systems (ICEES)*, Mar. 2016, pp. 35–38, doi: 10.1109/ICEES.2016.7510591.

## BIOGRAPHIES OF AUTHORS





**Indhana Sudiharto**    was born in Madiun, Indonesia in 1966. He received the Bachelor of Engineering degree in Power System from Sepuluh Nopember Institute of Technology, Indonesia in 1996, and Master of Engineering degree in Power System from Sepuluh Nopember of Institute of Technology, Indonesia in 2006. He is currently an Associate Professor with the Department Electrical Engineering, Politeknik Elektronika Negeri Surabaya (PENS), Indonesia. He joined the Division of Industrial Electrical Engineering, Department of Electrical Engineering, Politeknik Elektronika Negeri Surabaya (PENS), Indonesia, as a Lecturer, in 1996. He heads the research group of Power Quality PENS. His research interests include power systems, renewable energy, and power electronics. As a lecturer, he has taught subjects such as electrical measurement and instrumentation, electrical power system protection, and power quality. He can be contacted at email: indhana@pens.ac.id.



**Farid Dwi Murdianto**    was born in Malang, Indonesia in 1991. He received the Bachelor degree in Applied Engineering in Industrial Electrical from Politeknik Elektronika Negeri Surabaya (PENS), Indonesia in 2013 and the Master of Engineering degree in Power System from Sepuluh Nopember Institute of Technology, Indonesia in 2015. He is currently a Head of Central Intellectual Property Rights at Politeknik Elektronika Negeri Surabaya (PENS), Indonesia. He joined the Division of Industrial Electrical Engineering, Department of Electrical Engineering, Politeknik Elektronika Negeri Surabaya (PENS), Indonesia, as a Lecturer, in 2015. He joined several research groups including Power Quality, Energy Conservation and Power Electronic, and Electric Drive at PENS. His research interests include renewable energy and power electronics. As a lecturer, he has taught subjects such as renewable energy, power quality and microcontrollers. He can be contacted at email: farid@pens.ac.id.



**Lavia Isnani**    was born in Probolinggo, Indonesia in 2000. He received the Bachelor degree in Applied Engineering in Industrial Electrical from Politeknik Elektronika Negeri Surabaya (PENS), Indonesia in 2022. Currently, she is doing the final project research in Power Electronics, specifically charging systems. Her areas of interest include power electronics, renewable energy control systems, and power quality. She can be contacted at email: laviaisnani@gmail.com.