



PAPER • OPEN ACCESS

Design and Simulation Multilevel Boost Converter Using PI Controller Ziegler Nichol Method

To cite this article: M B Kurniawan *et al* 2021 *IOP Conf. Ser.: Mater. Sci. Eng.* **1096** 012062

View the [article online](#) for updates and enhancements.

You may also like

- [Design of a networking bolted joints monitoring method based on PZT](#)
Yang Yang, Guangmin Zhang, Yu Wang et al.
- [Application of feed forward neural network model to predict the limiting current of tin magneto electrodeposition](#)
Sudibyo, N Aziz, A Wijaya et al.
- [Robust Beamforming and Power Minimization Design in MISO Health Monitoring System](#)
Mingjun Pei, Xuemeng Jia, Rong Fu et al.

ECS The Electrochemical Society
Advancing solid state & electrochemical science & technology

247th ECS Meeting
Montréal, Canada
May 18-22, 2025
Palais des Congrès de Montréal

Showcase your science!

**Abstracts due
December
6th**

Design and Simulation Multilevel Boost Converter Using PI Controller Ziegler Nichol Method

M B Kurniawan¹, M Z Efendi² and F D Murdianto³

^{1,2,3}Department of Electrical Engineering, Electrical Engineering Polytechnic in Surabaya (EEPIS), Surabaya, East Java, Indonesia

Email: ^{a)}bgoeszk@gmail.com, ^{b)}zen@pens.ac.id, ^{c)}farid@pens.ac.id

Abstract. This Paper is explain about how to design a *Multilevel Boost Converter (MLBC)*. This Converter is a *Boost Converter* with an upgrade of Parallel Diode Circuit and Capacitors Circuit. *MLBC (Multi Level Boost Converter)* have more advantages with low voltage input change to high voltage output. The Principle of *MLBC* is like the *Boost Converter*, but they have high ratio conversion without adding transformation for step up the voltage, the *setting Output* will stabilize if they always get the minimum input range for reduce the drop voltage from input who used *Solar Panel*, it is used *MISO (Multiplied Input Single Output)*, the *MISO* contains *Solar Panel* and *Battery* with the parallel circuit set. *DC Micro Grid* using as *DC BUS* for distributed the voltage from the source to load for the maximum output power it used 100-200 Watt. The Method of control voltage it used PI - Ziegler Nichols-1 for controlled the *Multi Input Single Output (MISO)* block, the first control used to make the input of MLBC stabilize for 30 - 40 V being step up to 200 - 250 Volt. The Load of *DC BUS* example: *Inverter ,3 Phase Motor, Led DC, Battery Energy Storage* at this project used a inverter with 3 phase motor for load of converter. The Maximum Output Power from a design of this converter is 234.87 Watt according the DC load and the efficiency of converter is maximum 86 %.

1. Introduction

In the current time The Renewable energy being the most important things to research about 20 years ago until now, the foreseen reduced of fossil fuel-based energy sources and also the still high consumption demand of energy in the modern society for industrialization and manufacturing, they have been the major driving forces to seek for develop more clean and renewable alternatives. There is also an urgent need to solve the global environmental concern, to reduce the emission of carbon dioxide (CO₂) [1]. The energy consumption will the most cruel thing, their energy demand, and the load variations have to be assessed carefully. The distribution of the energy bought from the market (like electricity). The efficiencies at the consumption points, and the losses are determined. Not only the momentary values, but also the daily, weekly, and annual variations have to be considered. From the data, information like the average energy consumption, deviation from these values, and the energy per product can be calculated [2].

Photovoltaic / Solar Panel is the efficient Energy sources which is used on a tropical state area ,but the output of this Solar Panel is not stabilize [3][4]. It is must be control with a system stabilize control like PID, Fuzzy, NN, or GA. The Voltage stability is set using controls. Controls that are used are various kinds ranging from CV (Constant Voltage), PID Controller, Fuzzy Controller, and AI Controller. In this paper, PI-Ziegler Nichol 1 Controller is used as an output voltage control. DC micro grid systems have



relatively less power than DC grids because they are used for small loads. The efficiency of the DC network is very good compared to the AC network it's just that the cost of making and maintenance is more expensive, so rarely uses this DC network. One of them is a battery that must be treated or replaced with cables that have a diameter greater than the AC network. Current loads use more DC loads such as DC lights, Smartphones, Laptops, and other equipment.

DC Non-Isolated DC Converters are converters that can be made very simply requiring only Inductors, Capacitors, Resistors and Switching Components. This converter has a pretty good efficiency but cannot be compared to Isolated DC-DC Converters. One of the Non-Isolated DC-DC Converters is Boost Converter which is a converter that serves as a DC voltage booster from a low to high voltage value, this converter can increase the voltage 2-fold or more, only when above twice the efficiency will . Then an additional circuit is needed, namely the Multilevel Circuit, a circuit that uses capacitors and diodes as voltage boosts many times the input voltage [4][5][6]. The use of Non-isolated dc-dc converter coupled with multilevel circuits in this case Multilevel Boost Converter can increase the efficiency of the converter. The input voltage of MLBC (Multilevel Boost Converter) from small voltage becomes large [7]. Without this circuit we needless the transformation for change the low voltage to high voltage [8].

Solar Panel or Solar Cell is used as a solar energy generator that is converting from sunlight into electrical energy [9]. Weather conditions are very influential on the results of the Solar Cell in order to obtain maximum results there are many ways, ranging from the use of controls on the converter, the use of hybrid systems or changing energy with other energy sources when the energy cannot produce for example hybrid Solar Cells with PLN, and the use of circuits Multi Input Or the addition of several inputs with a series or parallel circuit. The use of Multi Input can increase the ability of Solar Cell because by using the MISO (Multi Input Single Output) circuit can increase the output of the Solar Cell by making series circuits with other sources, for example with batteries [10]. In this project we explain how to design and make a simple MLBC with MISO converters and controlled by PI-ZN controller [11].

2. Overall System

After studying and understanding the literature studies that are available, in this study a voltage booster is able to work to increase the voltage from small to large voltage using MLBC, the source of this converter uses MISO as 2 sources in parallel so that it will always be obtained stable voltage on the input side, next is to make a plan of the system includes:

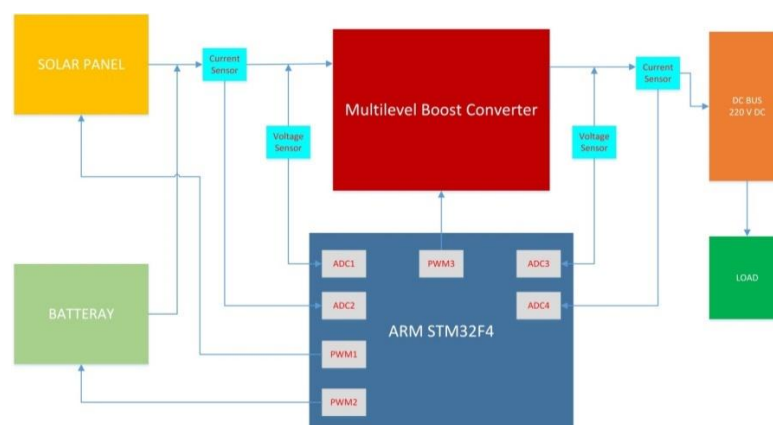

Figure 1. Block Diagram

In Figure 1 explains that the source comes from PV and batteries that are connected in Parallel or also called MISO (Multi Input single Output) blocks / circuits. Then the source is input to MLBC (Multi Level Boost Converter). The output of MLBC will make the input voltage increase by the multiplier in the MLBC module. Input voltage from MISO will be controlled using relatively stable input using PI –

Ziegler Nichol control on MLBC will make the Output Stable voltage of 200-230 V. The output will be used as DC BUS supply on the microgrid system, which can be used as an input inverter, DC led lights and other loads with a maximum power of 150 W. The block diagram will explain in the next paragraph.

2.1. Multi Level Boost Converter (MLBC)

The Multilevel Boost Converter is a dc-dc converter based on Pulse width Modulation (PWM) which combines conventional converter boost and switched capacitor functions to produce a different and stable output voltage using only 1 driven switch, 1 inductor, 2N-1 diode and 2N -1 capacitor. N in question is the number of levels in the multilevel boost converter. This converter is built with several levels that can be added without modifying or changing the main circuit and can use high switching frequencies. The multilevel boost converter circuit is shown in Fig. 2.

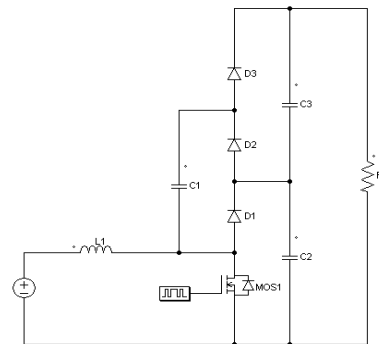

Figure 2. Multi-Level Boost Converter Basic Circuit

This characteristic can be achieved thanks to the multiplication of the conventional boost converter output voltage controlled by just one switch in the converter. So it is possible to obtain the output voltage of the multilevel boost converter as follows.

$$V_{out} = V_{in} \left(\frac{1}{1-D} \right) \times N \tag{1}$$

Where N is the number of levels of the multilevel boost converter topology. From Figure 1.2 the inductor current in the multilevel boost converter circuit is the same value as the input current. Then the average current of the inductor can be calculated as follows.

$$I_l = \left(\frac{N^2 V_c}{(1-D)R_{out}} \right) \tag{2}$$

Where [A] is the inductor current, [V] is the capacitor voltage, and R_{out} [ohm] is the load resistance. Inductance inductors on multilevel boost converters have lower values than conventional boost converters. The value of the inductor can be found as follows.

$$L_{min} = \frac{R_{out} \times (1-D)^2}{2 \times N^2} \times D \times T \tag{3}$$

$$L = L_{min} \times 10 \tag{4}$$

Where [Henry] is the minimum inductance inductor and T is the period. While the voltage ripple of the multilevel boost converter can be calculated as follows.

$$\Delta V_o = \frac{V_o \times D}{f \times C \times R} \tag{5}$$

$$\Delta V_o = \frac{I_o \times D}{f \times C} \tag{6}$$

Where [V] is the ripple voltage, f [Hz] is the frequency, [A] is the output current, and C [Farad] is the capacitance of the capacitor. Then to determine the value of the capacitor of the multilevel boost converter is as follows

$$C_{MLBC} = \frac{I_O \times D}{f \times \Delta V_O} \tag{7}$$

2.2. Multi Input Single Output (MISO)

Non-Isolated DC-DC Converter Single-Output (MISO) is presented in Figure 3 Input voltage sources are presented as Vin 1 and Vin 2, there are 2 switches there are 2 loops that have functions as positive boost and negative boost, which are connected with a capacitor that functions as an output capacitor, to produce steady state results can be seen in the equation in Table 1, when the voltage at the inductor is the same as the input source voltage when both sides of the on condition (d1, d2), this is the same as the condition diode off.

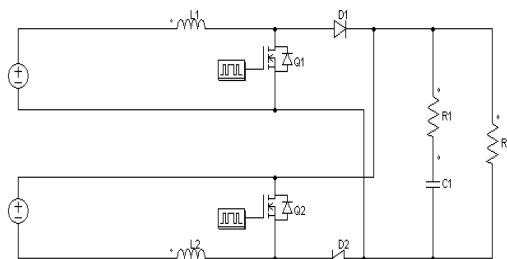

Figure 3. Multi Input Single Output Boost Converter

Table 1. Steady State Equation

Switching State	V_{L1}	V_{L2}
d_1, d_2	$V_{L1} = V_1$	$V_{L2} = V_2$
$(1 - d_1), (1 - d_2)$	$V_{L1} = V_1 - V_{out}$	$V_{L2} = V_2 - V_{out}$
$(1 - d_1), d_2$	$V_{L1} = V_1 - V_{out}$	$V_{L2} = V_2$
$d_1, (1 - d_2)$	$V_{L1} = V_1$	$V_{L2} = V_2 - V_{out}$

D value is determined based on the specified output value. After V_1 and V_2 correspond to the voltage value, the value of V on the main inductor is the sum of the voltage values V_1 and V_2 because they are arranged in parallel.

$$V_{out} = \frac{V_1 + V_2}{(2 - d_1 - d_2)} \tag{8}$$

Then when S1 On then the DC-DC Converter will issue a voltage in accordance with the value at V_1 . When S2 is ON then the read value is the same as the value of V_2 , if both are ON then the value of V_{out} is the addition of both.

2.3. PI-Ziegler Nichols

The Ziegler-Nichols tuning method is a heuristic method of PID controller tuning. It was developed by John G. Ziegler and Nathaniel B. Nichols. This is done by setting profits I (integral) and D (derivatives) to zero. The "P" gain (proportional), the K_p value is then increased (from zero) to reach the highest gain in the K_p value, which is the biggest gain where the output of the control loop has a stable and consistent oscillation, a gain higher than the final gain K_U has an oscillation different. and the controller oscillation period that is used and the desired behaviour, this can be seen in Table 2 Ziegler Nichols Equation.

Table 2. Equation Ziegler Nichols

Control Type	K_p	T_I	T_D
P	$\frac{T}{L}$	∞	0
PI	$0.9 \frac{T}{L}$	$\frac{L}{0.3}$	0
PD	$1.2 \frac{T}{L}$	$2L$	$0.5L$

After making a step-change in the output signal with the controller in manual mode, the trend of the process variable is carefully analyzed for two prominent features: dead time and reaction rate. Dead time (L) is the amount of time delay between changes in step-output and the first indication of changes in process variables. The reaction rate is the maximum level at which the process variable changes following the change in output step (the maximum time derivative of the process variable). Unfortunately, Ziegler and Nichols chose to refer to dead time with the word lag. In modern technical language, "lag" / time lag refers to first-order exponential function, which is fundamentally different from dead time from the Fig. 4.

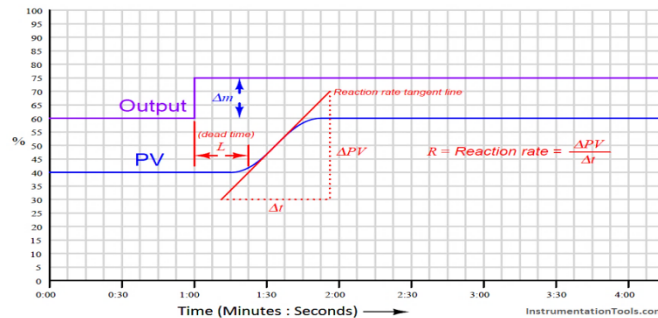

Figure 4. Define the Parameter of PI-Ziegler Nichols

If the controller in question is only proportional (unable to provide integral or derived control actions), Ziegler and Nichols' recommendation is to set the controller gain as follows:

$$K_p = \frac{\Delta_m}{RL} \tag{9}$$

Where,

- K_p = Controller gain value that you should enter into the controller for good performance
- Δ_m = Output step-change magnitude made while testing in open-loop (manual) mode (percent)
- R = Process reaction rate = $\Delta PV/\Delta t$ (percent per minute)
- L = Process dead time (minutes)

If the controller in question has integral (reset) action in addition to proportional, Ziegler and Nichols recommendation is to set the controller gain to 90% of the proportional-only value, and to set the integral time constant to a value just over three times the measured dead time value:

$$K_p = 0.9 \frac{\Delta_m}{RL} \tag{10}$$

$$t_i = 3.33 L \tag{11}$$

Where,

- K_p = Controller gain value that you should enter into the controller for good performance
- Δ_m = Output step-change magnitude made while testing in open-loop (manual) mode (percent)
- R = Process reaction rate = $\Delta PV/\Delta t$ (percent per minute)

L = Process dead time (minutes)

t_i = Controller integral setting that you should enter into the controller for good performance (minutes per repeat)

3. System Modelling

3.1 Modelling Multilevel Boost Converter

Voltage derived from Multi Input Single Output Block (MISO) blocks from Solar Panels and Batteries will be increased by using Multilevel Boost Converter (MLBC), this converter can increase the output voltage up to 10 times the input voltage depending on the number of levels to be used, if the more the output voltage value will be even greater. A series image of the multilevel boost converter is shown in Fig. 5.

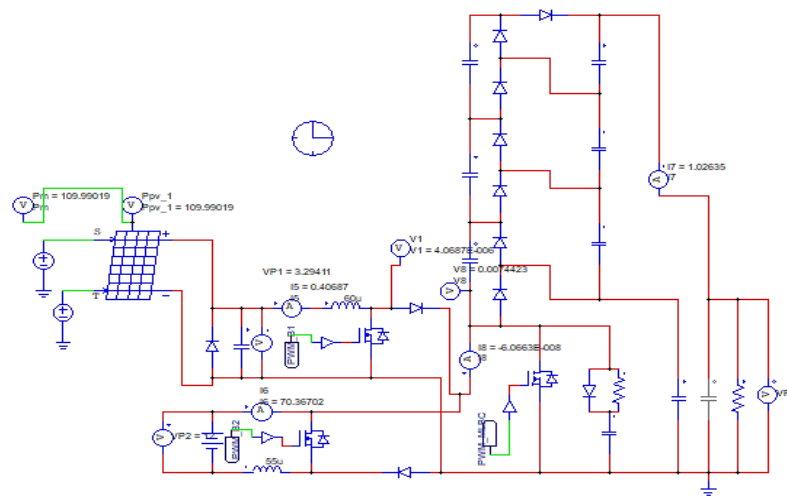

Figure 5. Multilevel Boost Converter with Multi Input Single Output circuit

D value is set based on the specified output value we set the $V_{out}MISO = 30 V$. After we have the value $V_1 = 18 V$ and $V_2 = 12 V$, we can know the output voltage from MISO converter. The value of d_1 & d_2 can be set in the equation. In this project we use 4N-3 multilevel setting $N = 4$ or multiple by 4.

$$V_{out}MISO = \frac{V_1+V_2}{(2-d_1-d_2)} \tag{12}$$

This multilevel boost converter can be set $V_{out}MLBC = 220 V$ the value of D we can use the equation to find it, the N value determine by the number of capacitor and diode of the MLBC ,in this project we used, $N = 4$.

$$V_{out}MLBC = V_{in} \left(\frac{1}{1-D} \right) \times N \tag{13}$$

After we calculate we have a parameter for MISO MLBC, show at Table 3, the parameter is include to MISO and MLBC circuit the input source voltage from the MISO circuit the output MLBC connected to DC Grid For DC BUS to Load.

Table 3. Parameter Multilevel Boost Converter

Parameters	Symbol	Value	Units
V input MISO	V_{IN}	30	Volt
V output	V_{OUT}	220	Volt

Current Ripple	ΔI_L	1.354	A
Voltage Ripple	ΔV_{RPL}	0.019	Volt
Frequency switching	fs	40	Khz
Inductor 1	L1	55	uH
Inductor 2	L2	60	uH
Capasitor MLBC	C1	75	uF
Capasitor out	C ₂	2.747	uF
Resistor	R	220	ohm

3.2 Modelling PI-Ziegler Nichols

Controller we used are Ziegler and Nichols the value of parameter we must know signal output when open loop and then we can determine the parameter Δ_m , R, & L. From the Fig. 6 we can determine the parameter.

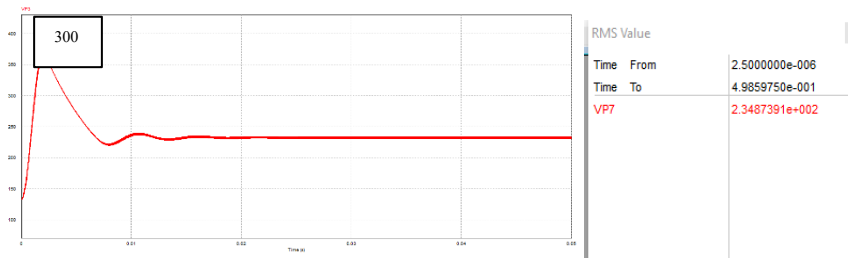

Figure 6. Signal Output Converter Open Loop without controller

$$R = \frac{\Delta_{PV}}{\Delta_t} \tag{14}$$

$$K_p = \frac{0.5}{15.347 \times 0.0007783} = 41.86 \tag{15}$$

After we know the parameter of the first equation we can know the parameter PI –Ziegler Nichols with the equation (3.5) and (3.6).

$$K_p = 0.9 \frac{\Delta_m}{RL} = 37.677 \tag{16}$$

$$t_i = 3.33 \times 0.0007783 = 2.592 \times 10^{-3} \tag{17}$$

4. Simulation & Discussion

In this study, the MLBC MISO was simulated using PSIM software. In this simulation the MISO voltage is 30-35 Volts as input from MLBC, the output from MLBC is 220 - 250 V. This simulation can be seen in Figure 7 The output from converter after being controlled by PI-Ziegler Nichols, we can see at Fig. 7. From that figure we know the PI-ZN have a better response than a regular PI controller.

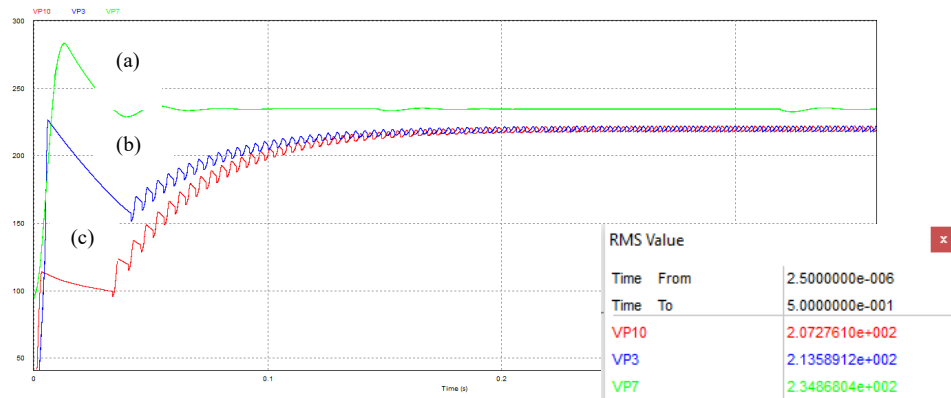

Figure 7. Signal Output Converter close loop (a) without controller, (b) with controller PI – ZN, (c) with controller PI

Table 4. Simulation Result with controller

$V_{IN}MLBC$	$I_{IN}MLBC$	$V_{out}MLBC$	$I_{out}MLBC$	$P_{IN}MLBC$	$P_{out}MLBC$
(V)	(A)	(V)	(A)	(W)	(W)
34.52	21.9	228	1.03	755.98	234.84
33.55	23.27	227.37	1.03	776.05	234.19
32.41	24.04	226.35	1.02	779.13	230.87
32.31	23.94	226.23	1.02	773.5	230.75
29.12	26.76	222.97	1.01	779.25	225.19

The experiment simulation table can see at Table 4 who show the input from the MLBC and Output MLBC to DC BUS. From the Table we know the output of the MLBC is 234.84 - 225.19 Watt, with the variant value of source from solar panel and battery.

Table 4 Simulation Result The Output from converter which close loop with controller make the steady state to setting voltage more fast than the open loop process, with the analyze we can summary the Ziegler Nichol controlled is better than the Open loop. For the Table 5, it contains the circuit performance with different duty cycle, and same source, without control.

Table 5. Simulation Result performance without control

$V_{IN}MLBC$ (V)	$I_{IN}MLBC$ (A)	Duty Cycle (%)	$V_{out}MLBC$ (V)	$I_{out}MLBC$ (A)	Efficiency (%)
31.53	6.28	50	194.6	0.884	86
31.49	5.83	55	187.4	0.851	86
32.19	6.34	60	196.77	0.89	85.8
32.51	8.31	65	222.58	1.01	83.2
35.24	10.2	70	250.22	1.13	78.66

5. Analyze and Conclusion

In this research, MISO MLBC uses PI-Ziegler Nichols controller. This system is able to work to increase the DC voltage with 2 sources consisting of a solar panel and battery, the DC load used is 150 W inverter with 220 volt voltage set. Changes that occur to the two sources, which occur due to cloudy or depleted battery energy are controlled using the PI-Ziegler Nichols controller, which will always stabilize the output according to the setting value.

In this system using PI-ZN, it has a faster response result compared to PI control. The Maximum Output Power of this converter is 234.87 Watt according the DC load. At the performance of circuit MLBC without control, an efficiency of converter is maximum 86 %. The voltage control when using PI-ZN mostly constant at 222.97 – 228 Volt according the sources when it solar panel being cloudy an the I radian of sun being drop at set point 220 Volt.

References

- [1] Yongheng Yang, Katherine A. Kim, Frede Blaabjerg, Ariya Sangwongwanich, 2019, "Advances in Grid-Connected Photovoltaic Power Conversion Systems".
- [2] Erdal IRMAK, Naki GULER, 2017, "Application of Boost Based Multi-Input Single-Output DC/DC Converter". 6th International Conference on Renewable Energy Research and Application".
- [3] Tanay Sidki Uyar, Towards 100% Renewable Energy Techniques, Costs and Regional Case-Studies, 2017.
- [4] C.A. Villarreal-Hernandez, J.C. Mayo-Maldonado, J.E. Valdez-Resendiz, J.C. Rosas-Caro, 2017 "Modeling and Control of an Interleaved DC-DC Multilevel Boost Converter".
- [5] Mona Chorishiya, D K Palwalia N Department of Electrical Engineering Rajasthan Technical University Kota, India, 2019, "A Review : Multilevel Hybrid Ultra-Boost Converter Topologies for PV Solar Application".
- [6] Hari Priya T, Alivelu M. Parimi, 2016, "Design of Adaptive Perturb and Observe-Fuzzy MPPT Controller for High Voltage Gain Multilevel Boost Converter".
- [7] Rafael Cisneros, Matteo Pirro, Gilbert Bergna, Romeo Ortega, Gianluca Ippoliti, Marta Molinas, 2015, "Global tracking passivity-based control of bilinear systems: Application to the interleaved boost and modular multilevel converters".
- [8] Mahajan Sagar Bhaskar, S. Padmanaban, Frede B., 2016, "Inverting Nx and 2Nx Non-Isolated Multilevel Boost Converter For Renewable Energy Applications".
- [9] V. Anil Kumar, Dr. M. Arounassalame, 2017, "PV-FC Hybrid System with Multilevel Boost Converter Fed Multilevel Inverter with Enhanced Performance".
- [10] Mario González, Víctor Cárdenas, Homero Miranda, Ricardo Álvarez-Salas, 2019, "Modular multilevel converter for large-scale photovoltaic generation with reactive power flow and unbalanced active power extraction capabilities".
- [11] Arash Abedi, Behrooz Rezaie, Alireza Khosravi, Majid Shahabi, 2020, "DC-bus Voltage Control based on Direct Lyapunov Method for a Converter Based Stand-alone DC Micro-grid".