

PAPER • **OPEN ACCESS**

## Optimal power flow using particle swarm optimization for IEEE 30 bus

To cite this article: K Widarsono *et al* 2020 *J. Phys.: Conf. Ser.* **1595** 012033

View the [article online](#) for updates and enhancements.

You may also like

- [THE PAN-STARRS1 DISTANT  \$z > 5.6\$  QUASAR SURVEY: MORE THAN 100 QUASARS WITHIN THE FIRST GYR OF THE UNIVERSE](#)  
E. Bañados, B. P. Venemans, R. Decarli et al.
- [Ensemble classifier based on optimized extreme learning machine for motor imagery classification](#)  
Li Zhang, Dezhong Wen, Changsheng Li et al.
- [FIRST RESULTS FROM Pan-STARRS1: FAINT, HIGH PROPER MOTION WHITE DWARFS IN THE MEDIUM-DEEP FIELDS](#)  
J. L. Tonry, C. W. Stubbs, M. Kilic et al.



**ECS** The Electrochemical Society  
Advancing solid state & electrochemical science & technology

**ECS UNITED**

**247th ECS Meeting**  
Montréal, Canada  
May 18-22, 2025  
*Palais des Congrès de Montréal*

**Showcase your science!**

**Abstracts due  
December  
6th**

# Optimal power flow using particle swarm optimization for IEEE 30 bus

K Widarsono<sup>1</sup>, F D Murdianto<sup>2,\*</sup>, M Nur<sup>1</sup>, and A Mustofa<sup>1</sup>

<sup>1</sup>Electrical Industrial Engineering Department, State Polytechnic of Madura, Indonesia

<sup>2</sup>Electrical Engineering Department, Electronic Engineering Polytechnic Institute of Surabaya, Indonesia

\*Corresponding author: farid@pens.ac.id

**Abstract.** Particle Swarm Optimization (PSO) is one of the algorithm intends to get minimum or maximum value of a function, based on the behavior of a bird flocks. In this research, PSO has implemented to overcome the problem of power flow in the plant. The search for solutions is carried out by a population of several individuals. Population is the representation of a generator in electric power distribution system. The plant used in this study is IEEE 30 bus. There are 6 plants which must be optimized. PSO generate one power value in each generator as a reference value. This value will be shifted by increasing or reducing it, until the optimal generation value is found for all plants. The result of the experiment proved that PSO is able to solve power flow optimization problems on IEEE 30 bus, indicated by the individual rate in each population, the rate of fitness and the rate of generation can reach its convergence. This convergence rate is strongly influenced by the value of Velocity on the PSO. With PSO method, the IEEE 30 bus system can generate optimal power of 193 MW.

## 1. Introduction

Electrical energy is important component in human life. Electricity takes a leading role as indicators of a nation's progress, but now the availability of electrical energy is decreasing. Therefore, for the last 30 years, many researchers continue to think of finding new energy sources to maintain the sustainability of electricity. In addition to the availability of electrical energy, how to distribute and how to maintain the quality of electric power are the main factors in the electricity system.

In electrical energy there are 3 main components, generation, transmission and distribution. Of the three components, transmission and distribution are components that experience a lot of interference. Many methods are proposed to overcome these problems. Maintenance of intelligence-based transmission and distribution network equipment [1]. Combine UPFC power flow and economic equipment delivery requests, using the optimal power flow control method based on UPFC's minimum capacity [2]. The optimal combination of parameterization methods in voltage stability analysis with continuous power flow to improve the efficiency of continuous power flow and hybrid power flow calculations [3]. This research focus to numerical method and included voltage stability during getting optimal power flow [1-3].

Implementation power electronic in energy management system [4]. Micro grid power flow optimization has also been researched [5]. This optimization combines the main network with small scattered plants (wind and solar cells). These scattered small generators are used to support larger main



networks. The influence of the micro grid on the main system power flow has also been researched [6]. Application of power electronics to obtain optimal power flow [7]. Based on Hanna et al., Dent et al., and Noguchi et al. [5-7] focus to impact micro grid to power flow in large system.

Some artificial intelligence applications on power flow optimization problems have also been carried out. Application of genetic algorithms and neural networks in optimal power flow to obtain low costs [8]. The application of genetic algorithms in power flow with limits on voltage security has been carried out [9]. This research focus to implementation artificial intelligent in power system [8-9].

The application of particle swarm optimization on work hours scheduling has been done [10]. Multi-objective differential evolution method use to optimized the train operation planning [11]. Fractional swarm intelligent computing with entropy evolution use to optimal power flow [12]. From the literature has been studies, we know that previous studies have used artificial intelligence to optimize power flow and some studies mathematical functions (Newton Raphson, Lagrange etc.). In addition, they try to install additional equipment to make the optimal power flow. This research offered the application of particle swarm optimization to obtain optimum power flow on the IEEE 30 bus system and in the fitness result of this research has compared with genetic algorithm.

## 2. Methods

### 2.1. Bus Parameter

The optimal power flow here will be applied to the IEEE 30 bus system. This system has 6 generators and 41 channels. The generator is installed on buses 1, 2, 13, 22, 23 and bus 27. The generator on bus 1 acts as a generator or slack bus.

The types of buses on the IEEE 30 bus system are given as follows:

- One slack bus, and the generator bus on bus 1.
- 5 bus generators
- 30 bus loads

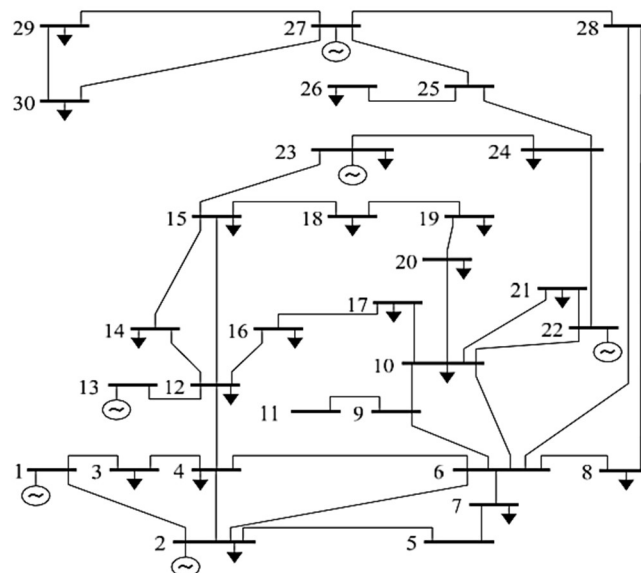

**Figure 1.** Single line diagram of IEEE 30 bus

Figure 1 shows the topology of the IEEE 30 bus system. There have 30 grid buses with 6 generators on bus 1, 2, 13, 22, 23 and bus 27. The channel impedance or  $Z$  value in the system is expressed in units of  $\Omega$  (Ohm). To simplify the calculation, the unit must be changed to p.u (per unit) value.

### 2.2. Channel Parameters

The other bus parameters specified are Z base. The Z base value on the channel can be determined using the following formula.

$$Z_{\text{base}} = \frac{(kV_{\text{base}})^2}{\text{MVA}_{\text{base}}} \quad (1)$$

Calculation of Z values in units of p.u can be determined using a formula:

$$Z_{\text{p.u}} = \frac{Z_{\text{ohm}}}{Z_{\text{base}}} \quad (2)$$

After determining the bus and channel parameters, then the system is evaluated by power flow analysis to determine the stability of the system model. For large-scale electric power systems, the Newton-Rapshon method is very efficient and practical for obtaining large currents in the transmission and power which enter the bus. The form of complex power on bus i is expressed in the following formula.

$$p_i - jQ_i = |V_i| \angle \delta_i \sum_{i=1}^n |Y_{ij}| V_i \angle \theta_{ij} + \delta_i \quad (3)$$

### 2.3. Optimization Using The Lagrange Method

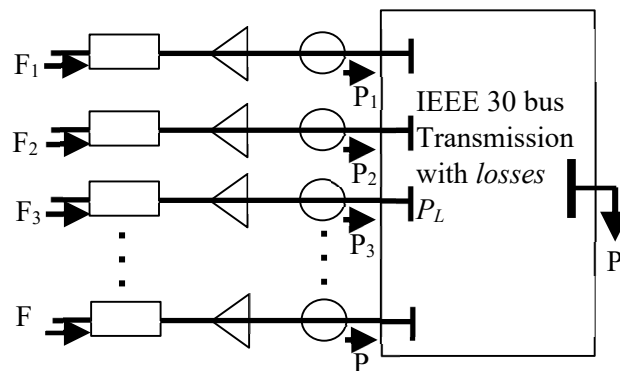

**Figure 2.** Generating unit with cost function

Mathematically, the problem can be written in objective function expressed in  $F_T$  which is equal to the total cost to supply the load and power loss in the transmission line.

$$F_T = F_1 + F_2 + F_3 + \dots + F_N = \sum_{i=1}^N F(P_i) \quad (4)$$

The solution to this problem is how to minimize  $F_T$  by paying attention to the limits that the amount of power generated must be equal to the load power including transmission losses. The mathematical form is

$$\min \sum_{i=1}^N F(P_i) = \min \sum_{i=1}^N (\alpha_i + \beta_i P_i + \gamma_i P_i^2) \quad (5)$$

#### 2.4. Partical Swarm Optimization

The PSO algorithm mimics the social behavior of an insect swarm. Social behavior consists of individual action and influence from other individuals in a group. Each individual or particle behaves in a distributed manner by using its intelligence and also influenced by collective group behavior. This algorithm optimizes the problem by moving individuals within the scope of the problem using the optimal function for the position and speed of the swarm. At each iteration each individual in the population will renew its position following the two best values, called the best solution for each individual (pBest) and the best solution in the population (gBest). After obtaining the two best values, the position and speed of individual movements are updated using the equation:

$$V_j(i) = V_j(i-1) + c_1 r_1 [pBest_j - x_j(i-1)] + c_2 r_2 [gBest - x_j(i-1)] \quad (6)$$

and

$$x_j(i) = x_j(i-1) + V_j(i) \quad (7)$$

One of the advantages of the PSO algorithm is that the acquisition of its convergence value is quite high and act as the basis for selecting this algorithm to be applied in the case of optimization of costs at the power plant. In the IEEE 30 bus problem, there are 6 plants represented as populations in the PSO algorithm. Each population has a number of individuals  $x_j(i)$  randomly generated with  $j$  being an indicator for each generator. These individuals will be used as particles in the PSO algorithm.

The process of PSO algorithm begins by generating a random population. It is selected through the Individual evaluation function and Flow Power function to obtain a number of individuals with appropriate fitness values. The best solution for each will be saved as pBest and the best solution for the population will be saved as gBest. Both of these values are continually updated until the pBest value for all individuals is converged. The pBest and gBest solutions will determine updates to the velocity value while updating individual values. The value of the last individual is reevaluated through the Individual Evaluation function and the Flow Power function to determine the update of pBest and gBest. This process will continue until the maximum number of iterations is fulfilled. The simple process of implementing PSO on IEEE 30 buses can be seen on Figure 3.

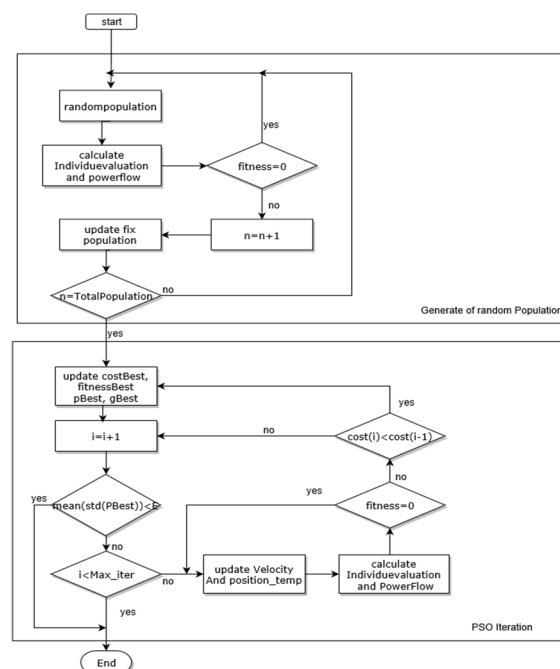

Figure 3. PSO flowchart on IEEE 30 bus system

### 3. Results and Discussion

To get the results on the IEEE 30 bus power flow optimization simulation using PSO. We limit the iteration to 2 conditions, the first condition is the number of iteration, the second condition is the individual difference in population. Whichever condition of those is reached first, the program will automatically stop. In this chapter from these experiments we obtained the following results.

#### 3.1. The Individual Movement In Each Population

Figures 4 and 5 show the movement of individuals from each population. This population is a representation of the generator on the IEEE 30 bus system. It shows that individuals start from the beginning moving towards convergent points and reach convergence at the 9th iteration. From each population / generator experiencing a rhythmic movement. Individual speed in achieving convergence is greatly influenced by its velocity.

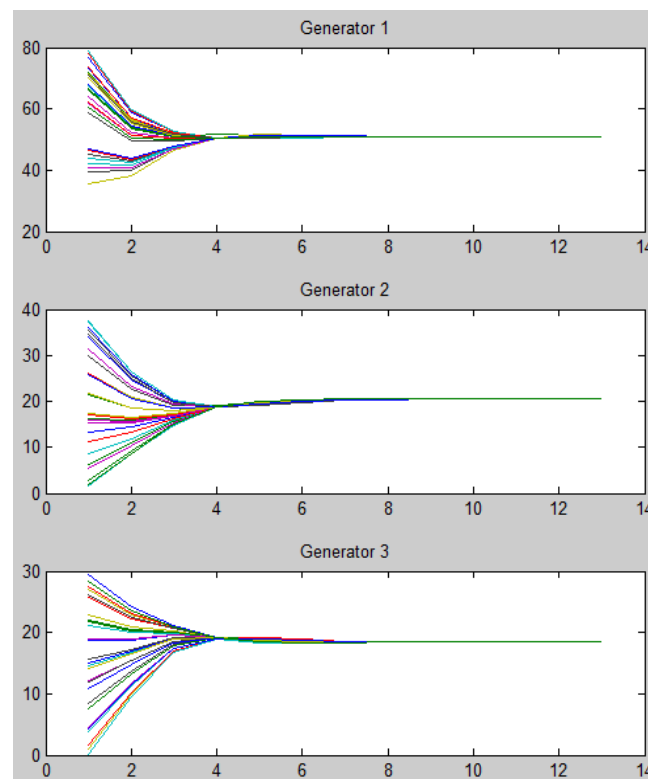

**Figure 4.** Movement of individuals in populations / generators 1-3

Figure 4 shows the movement of the population at generator 1-3 on the IEEE 30 bus system. The X axis represents the number of iterations and the Y axis represents the value of the power generated by the generator. In the initial iteration, each generator randomly generates one particular power value. The value is shifted through the PSO algorithm and reaches convergence on iteration 9. From the convergence result is obtained power generation at generator (1) 48 MW, generator (2) 20 MW and generator (3) 17 MW.

Figure 5 shows the movement of the population at generator 4-6 on the IEEE 30 bus system. The X axis represents the number of iterations and the Y axis represents the value of the power generated by the generator. In the initial iteration, each generator randomly generates one particular power value. The value is shifted through the PSO algorithm and reaches convergence on iteration 9. From the convergence result is obtained power generation at generator (4) 59 MW, generator (5) 31 MW and generator (6) 18 MW.

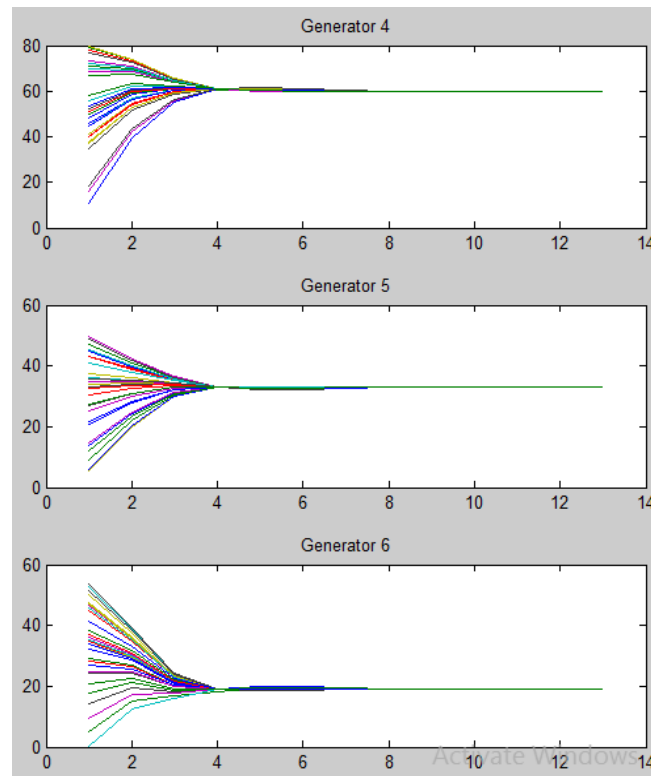

**Figure 5.** Movement of individuals in populations / generators 4-6

### 3.2. Cost Movement Rate

Figure 6 shows that the generation costs move towards convergence. Convergence of generation costs shows a minimum movement. Therefore, the cheapest generation costs are obtained.

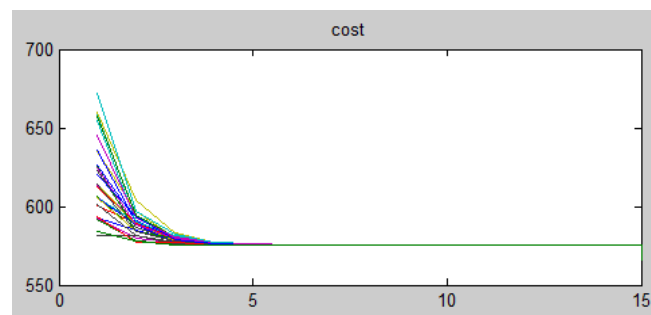
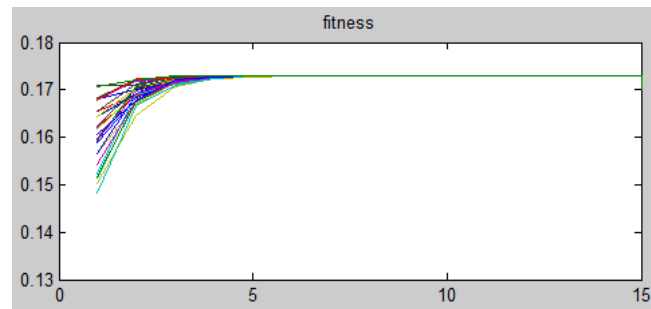

**Figure 6.** Cost movement in each population.

Difference with fitness, graph of cost generation from the first iteration to the last shows a smaller value. This is appropriate and this shows that the PSO algorithm works well for power optimization on the IEEE 30 bus system.

### 3.3. Fitness Movement Rate

Figure 7 shows the rate of fitness movement in each population. Fitness is a representation of the quality of individuals in the population. The higher the fitness value, the more optimal results will be obtained.



**Figure 7.** Fitness movements in each population.

The Figure 7 shows that the value of fitness in the first iteration until the last iteration always increases. This shows that the PSO algorithm can improve power optimization in each iteration and in the last iteration a fitness value of 0.173 is obtained.

### 3.3.1. Fitness comparison Genetic Algorithm (GA) and PSO

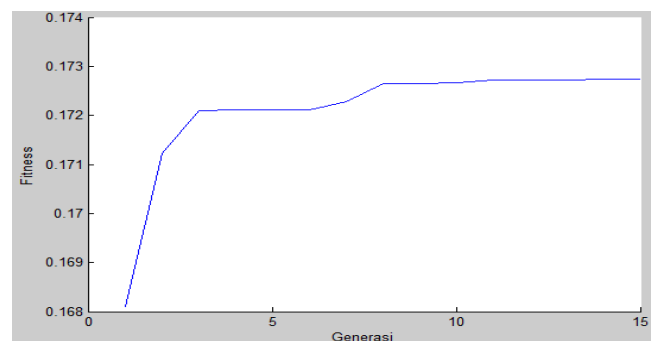

**Figure 8.** Fitness value of GA

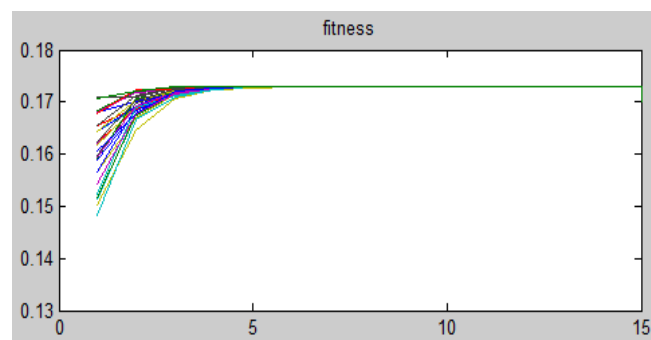

**Figure 9.** Fitness value of PSO

This chapter compare fitness value and iteration value of GA and PSO. Figures 8 and 9 show that PSO has need fewer iterations than GA to achieve fitness values. This figure also shows that the fitness values of GA and PSO are close (0.17). It proved that PSO is one of artificial intelegent that can be used to solve the optomation problem, special on power generation.

## 4. Conclusion

From simulation result obtained that individual variables in population, fitness and costs were able to reach the convergence value. The average time needed for this variable to reach the convergence point is 9 iterations in the PSO. From some of the images presented (power generation, fitness, and cost) it

can be seen that from iteration 9 to the final iteration, the system never goes out of convergence. These results prove that PSO is able to be an alternative solution in terms of optimization, in this case the PSO is implemented for IEEE 30 bus power flow optimization. For further research, researchers will try to implement this method to hardware with small system that can be representation the all system.

## References

- [1] Fumihiko Endo, Masaki Kanamitsu, Ryo Shiomi, Hiroki Kojima, Naoki Hayakawa, and Hitoshi Okubo, "Optimization of Asset Management and Power System Operation Based on Equipment Performance", International Conference on Condition Monitoring and Diagnosis, Beijing, China, April 21-24, 2008.
- [2] Zhang Zhi-hua ; Xu Bing-yin ; Chen Qing, "Research on the optimal Power Flow Control method of the closed-loop distribution network with UPFC". IEEE PES Innovative Smart Grid Technologies, 2012.
- [3] Xiangwen Cheng ; Xiaoke Chen ; Jinqun Zhao ; Lixuan Jia ; Jianzhi Liu, "Probe into optimal combination of parameterization in continuous power flow". International Conference on Natural Computation, Fuzzy Systems and Knowledge Discovery (ICNC-FSKD), 2017.
- [4] Murdianto, F.D., Efendi, M.Z., Widarsono, K., Azizi, M. "Robustness analysis of PID controller Bidirectional SEPIC/Zeta for Energy Management in DC Nanogrid Isolated System" International Conference on Information Technology, Information Systems and Electrical Engineering. 2018.
- [5] Blair Hanna ; Adel El-Shahat , "Optimal power flow for micro-grids". IEEE Global Humanitarian Technology Conference (GHTC). 2017.
- [6] C.J. Dent, L.F. Ochoa, and G.P. Harrison, "Network distributed generation capacity analysis using OPF with voltage step constraints". IEEE Transactions on Power Systems, 2010.
- [7] Toshihiko Noguchi, Akira Sato, and Daisuke Takeuchi, "Minimization of DC Reactor and Operation Characteristics of Direct-Power-Controlled Current-Source PWM Rectifier". 2006
- [8] Kuku Widarsono ; Akhmad Arif Kurdianto ; Farid Dwi Murdianto ; M. Sohibul Hjjah . "Comparison of sGA and SEGA Methods to Solve the Problem of Power Generation and Power Losses on Distributed Generating Systems". International Seminar on Application for Technology of Information and Communication. 2018.
- [9] Worawat Nakawiro ; Istvan Erlich, "A Combined GA-ANN Strategy for Solving Optimal Power Flow with Voltage Security Constraint". AsiaPacific Power and Energy Engineering Conference. 2009.
- [10] Tsung-Lieh Lin, Shi-Jinn Horng, "An efficient job-shop scheduling algorithm based on particle swarm optimization". Expert System With Applications. 2010.
- [11] Huixin Tian, Minwei Shuai, And Kun "Optimization Study of Line Planning for High Speed Railway Based on an Improved Multi-Objective Differential Evolution Algorithm". IEEE Access. 2019.
- [12] Yasir Muhammad, Rahimdad Khan, Muhammad Asif Zahoor Raja, Farman Ullah, Naveed Ishtiaq Chaudhary And Yigang He "Design of Fractional Swarm Intelligent Computing With Entropy Evolution for Optimal Power Flow Problems". IEEE Access. 2020.