



PAPER • OPEN ACCESS

Design and Implementation of Bipolar Sepic-Cuk Converter with Fuzzy Logic Control for Battery Charging Application

To cite this article: D J Triandy *et al* 2021 *IOP Conf. Ser.: Mater. Sci. Eng.* **1096** 012067

View the [article online](#) for updates and enhancements.

You may also like

- [Performance enhancement of EV charger with Cuk converter and ABC algorithm](#)
AVV Sudhakar, Y Manjusree and MS Teja
- [Optimized virtual impedance solar restoration droop emulated SEPIC controller under low irradiation](#)
Mukhraj Yadav and Navdeep Singh
- [PV Fed Grid Power Control by Discrete CUK Converter and SPWM Inverter Control Techniques](#)
K Vijji, K Chitra and M Lakshmanan

ECS The Electrochemical Society
Advancing solid state & electrochemical science & technology

247th ECS Meeting
Montréal, Canada
May 18-22, 2025
Palais des Congrès de Montréal

Showcase your science!

Abstracts due December 6th

Design and Implementation of Bipolar Sepic-Cuk Converter with Fuzzy Logic Control for Battery Charging Application

D J Triandy¹, E Wahjono², F D Murdianto³

¹ Department of Electrical Engineering, Politeknik Elektronika Negeri Surabaya. Surabaya, East Java, Indonesia

Abstract. This research presents the design of an electricity distribution system with a solar cell source that is applied to the battery charging process. The charging setting uses a modified DC-DC converter configuration from the modified Sepic and Cuk converters. With one Bipolar Sepic-Cuk Converter voltage source produces two outputs of the same voltage value with different polarities. The method applied is constant voltage, where the voltage generated by the solar panel will always be constant and the same in accordance with the setpoint specified in the charging process. The control used is a fuzzy logic control that functions to regulate the PWM output signal by getting the duty cycle value. The voltage sensor is used as feedback from the control to be processed by the microcontroller so as to produce a PWM signal which will be used to regulate switching on the Bipolar Sepic-Cuk converter circuit. The output voltage of the converter has been achieved with fuzzy control with irradiation and temperature variations. The results of the output voltage can be maintained at a predetermined voltage. The error percentage of the generated voltage is equal to 0.14 - 0.5%.

1. Introduction

The use of energy to meet the needs of human life plays an important role in the economic growth of a country. Solar cells are power plants that are able to convert sunlight into electric current. Problems arising from the use of solar cells that depend on environmental conditions where the amount of electrical energy produced depends on the intensity of light and temperature, thus making the power output in the system vulnerable to instability. Therefore we need a battery to store the energy produced during the irradiation process so that when the solar cell does not get solar radiation, the system already has the energy stored in the battery. With DC microgrid systems, energy can be transmitted in three types, namely monopolar, bipolar, and homopolar [2]. The advantages of bipolar type microgrid design can minimize power loss, if there is interference in one line, then the other line will continue to operate. Bipolar dc links have two different polarities, namely positive polarities and negative polarities with the same voltage output and good efficiency [3].

Bipolar Sepic-Cuk converter is a type of non-isolated converter that can be operated with 2 modes, namely boost mode and buck mode. In this paper, a bipolar converter system is designed using a Sepic-Cuk type converter that functions to charge batteries from solar panels. Where the main voltage of the solar panel used to supply batteries is 17.5 volts with the constant voltage method with a battery capacity of 12 volts 20 Ah in a low state (80%). The control of this system uses fuzzy logic control to keep the charging voltage stable.



2. System Design

In this research, a charging system was created which is capable of charging batteries where only one input voltage produces two voltage outputs with two different polarities.

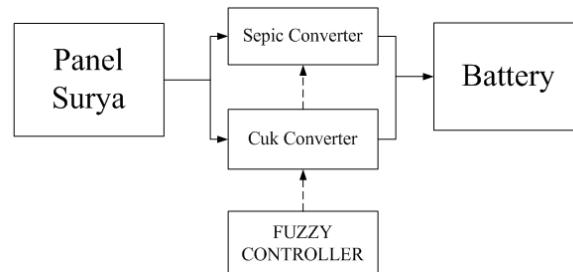

Figure 1. Overall system design

Figure 1 shows the overall system block diagram that will be examined in this paper. In a previous study, the method used to charge a battery was to use a PI control. Using the PI control produces a longer output response and produces a voltage ripple that is rated as not good [2]. Therefore to produce a faster output response the fuzzy control method is used and to maintain the output voltage of the converter the constant voltage method is used. The converter used in this paper is a bipolar sepic-cuk converter. The output voltage on this converter is kept stable with a constant voltage condition until the battery is fully charged.

3. System Modelling

3.1 Bipolar SEPIC - CUK Converter

A Microgrid is a low voltage network that is used independently or in a small and independent scope. The microgrid consists of three types, namely monopolar microgrid, bipolar microgrid, and homopolar microgrid. Of all these topologies, bipolar microgrids are widely used. The advantages of bipolar type microgrid design that can minimize power losses, if there is interference in one line, then the other line continues to operate. Bipolar dc links have two different polarities, namely positive polarities and negative polarities with the same voltage output and good efficiency.

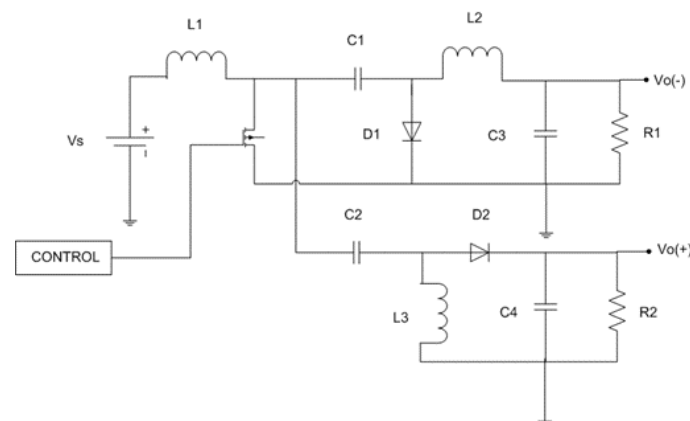

Figure 2. Bipolar SEPIC - CUK Converter

This research using a Bipolar Sepic-Cuk Converter which is a type of non-isolated converter that can be operated with 2 modes, namely boost mode and buck mode. The Sepic and Cuk converter has the same operating cycle so that the output voltage is also similar. This converter acts as a Buck or Boost Converter depending on the duty cycle. If the duty cycle value is greater than 50%, the converter functions as a boost, the response of the Sepic converter voltage value becomes positive and the voltage response of the cuk will be negative. When the duty cycle is less than 50%, this converter functions as

a buck, the response of the output voltage value will be in accordance with the polarities of the sepic and cuk converter.

The design of the sepic and cuk converters to combine two structures is capable of making bipolar type converters as shown in Figure 2. There is only one switch that is controlled to control both converters namely the sepic side and the cuk side. No need to synchronize multiple switches because the switch is connected to the ground. The bipolar sepic-cuk converter circuit has two operating modes, namely:

Mode 1: When switch S is turned on, the energy supplied by the input voltage is stored in L_1 and L_2 . The L_3 and L_4 inductors also store energy due to the discharge of capacitors C_1 and C_2 . During this interval, the freewheeling diode is dead or open. The energy supplied to the load is provided by the output capacitor.

Mode 2: When the S switch is off, the inductor refills capacitors C_1 and C_2 through the freewheeling diodes D_1 and D_2 and supplies power to the load.

The output voltage of the Sepic - Cuk converter is as follows:

$$V_o = -V_s \left(\frac{D}{1-D} \right) \quad (1)$$

To determine the value of the Inductor and Capacitor of SEPIC using the following equation:

$$L_1 = L_2 = \frac{V_s \cdot D}{\Delta I_L \cdot f} \quad (2)$$

$$C_1 = C_2 = \frac{V_{out} \cdot D}{R \cdot \Delta V_o \cdot f} \quad (3)$$

To determine the value of an Inductor of Cuk using the following equation:

$$L_1 = \frac{V_s \cdot D}{\Delta I_{L1} \cdot f} \quad (5)$$

$$L_2 = \frac{V_s \cdot D}{\Delta I_{L2} \cdot f} \quad (6)$$

To determine the Capacitor value of Cuk using the following equation:

$$C_1 = \frac{V_{out} \cdot D}{R \cdot \Delta V_{C1} \cdot f} \quad (7)$$

$$C_2 = \frac{(1-D)}{8 \cdot L_2 \cdot \Delta V_o / V_{out} \cdot f^2} \quad (8)$$

Where:

V_s = Input Voltage (V)

V_o = Output Voltage (V)

D = Duty Cycle (%)

I_{in} = Input Current (A)

I_{out} = Output Current (A)

ΔI_L = Inductor Ripple Current (A)

ΔV_o = Output Ripple Voltage (V)

ΔV_{C1} = Output Ripple Voltage C_1 (V)

L = Inductor (H)

R = Resistance(ohm)

F = Switching Frequency (Hz)

C = Capacitor (F)

Table 1. Results from Bipolar Sepic - Cuk Converter Calculations

Parameters	Symbol	Value	Unit
Input Voltage	V_{in}	17.5	Volt
Output Voltage	V_{out}	13.8	Volt
Input Current	I	5.72	A
Output Current	I	4	A
Inductor Ripple Current	ΔI_{L1}	1.144	A
Inductor Ripple Current	ΔI_{L2}	0.8	A
Inductor RMS Current	I_{LRMS1}	5.73	A
Inductor RMS Current	I_{LRMS2}	4.01	A
Switching Frequency	F	40	Khz
Inductor	L_1, L_2	67.461	μ H
Inductor	L_3	96.469	μ H
Output Ripple Voltage	ΔV_o	0.0138	Volt
Output Ripple Voltage	ΔV_{C1}	0.0313	Volt
Capacitor	C_1	1408.9	μ F
Capacitor	C_2	470	μ F

3.2 Solar PV Model

A solar cell is a device or component that can convert sunlight energy into electrical energy using the principle of the photovoltaic effect. The photovoltaic effect is a phenomenon in which the emergence of an electric voltage is due to the connection or contact of two electrodes that are connected to a solid or liquid system when getting light energy. Therefore, solar cells are often referred to as photovoltaic cells (PV).

Electric current arises because of the photon energy of sunlight it receives successfully liberating electrons in a type N and P-type semiconductor connection to flow. Just like a photodiode, this solar cell also has a positive foot and a negative foot that is connected to a circuit or device that requires a power source.

Table 2. Spesification Of PV

MIXENOC SOLAR MODULE		
Rated Power	(Pmax)	100 W
Open Circuit Voltage	(Voc)	22.0 V
Short Circuit Current	(Isc)	6.35 A
Rated Voltage	(Vmp)	17.5 V
Rated Current	(Imp)	5.72 A
Module Dimensions	-	1085 x 675 x 25 mm
Weight		8,7 kg
(IRRADIANCE OF 1000 w/m² AM1.5 SPECTRUM AND CELL TEMPERATURE OF 25 C)		

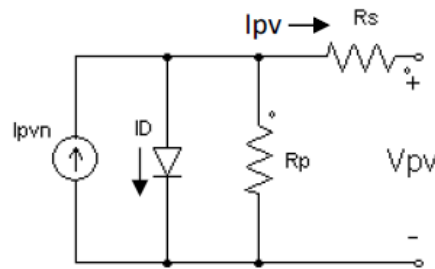

Figure 3. PV panel equivalent circuit

PV modeling equation using 1 diode.

$$I_{PV} = I_{PVn} - \left(I_0 \left(e^{\frac{V_D}{aV_T}} - 1 \right) \right) - \frac{V_{PV} + I_{PV} R_S}{R_P} \tag{15}$$

Where :

- I_{PV} = Solar Panel Output Current
- I_{PVn} = PV Panel Current
- R_S, R_P = series and parallel resistors
- I_0 = Reverse Saturation Current
- a = diode ideality factor
- V_T = thermal voltage

3.3. Modeling Fuzzy

In this research, the control used to adjust the output voltage of the converter to match the setpoint by using fuzzy logic control. The concept of fuzzy theory in the classical set, the value of membership is clear meaning that it is included in members that are valued at 1 or not included in members valued at 0. An element in a universe for fuzzy sets the nature of membership is vague or blurred. Fuzzy set contains elements that have varying membership values in a set. In the fuzzy control system that works between 0 and 1 can be defined so that the controller can work like a human nervous system that can feel the external scope that is less, somewhat, ordinary, very or even blurring can be more than that category by adding linguistic factors that are collected in the degree of membership.

By using a fuzzy logic controller, we get facilities that are not owned by conventional control systems. Among other things in the design of a controller does not need to find a mathematical model of a plant. While the fuzzy-based controller has several stages before going to the plant. These stages are fuzzification, rule base, and database then fuzzification. The fuzzy logic process is presented as shown in Figure 4.

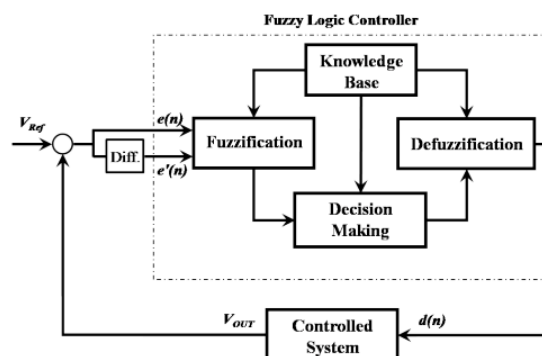

Figure 4. The basic structure of the Fuzzy system.

3.3.1 Fuzzifikasi

Fuzzification is the process of changing the input from a crisp form into fuzzy (linguistic variable) which is presented in the form of a fuzzy set with each membership function. Figure 5. and Figure 6. is the process of fuzzification.

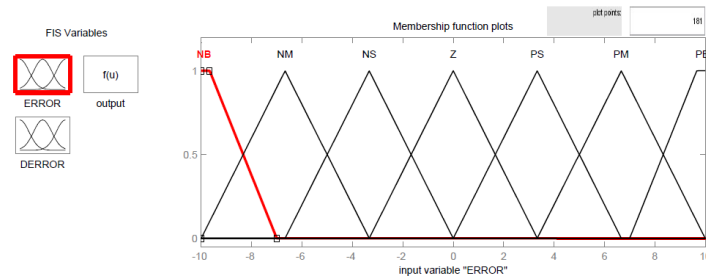

Figure 5. Input Variable Error

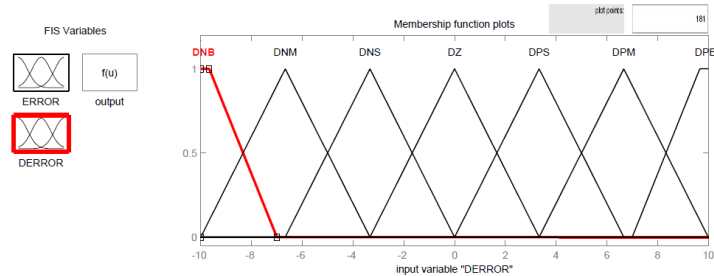

Figure 6. Input Variable Delta Error

3.3.2 Rule Base

The rule base consists of IF-THEN statements. Fuzzy rule base determination is made after the process of fuzzification, which consists of a set of rules based on fuzzy logic to declare a condition. This rule base arrangement affects the precision of the model, at the decision-making stage is determined based on the rule base design. Table 3 shows the rule base used in this research.

Table 3. Rule Base

E/ ΔE	NB	NM	NS	Z	PS	PM	PB
NB	NB	NB	NM	NM	NS	Z	Z
NM	NB	NM	NM	NS	Z	Z	PS
NS	NM	NM	NS	NS	Z	Z	PS
Z	NM	NS	NS	Z	Z	PS	PS
PS	NS	NM	Z	Z	PS	PS	PM
PM	Z	Z	Z	PS	PS	PM	PM
PB	Z	PS	PS	PS	PM	PM	PB

3.3.3 Defuzzyfikasi

The output of the rule base is still a fuzzy value, so the defuzzification process is needed to change the fuzzy value (linguistic variable) to a firm value which will then be sent to the system/plant. The defuzzification used in this system is the weighted average. In this method, each output membership

function above the value indicated by each fuzzy output is truncated. Using the weighted average fuzzification method, the output singleton values are combined using average weights. This method applies to fuzzy sets with symmetric output membership functions.

4. Simulation and Discussion

The simulation carried out in this research is to compare the output voltage of the uncontrolled bipolar sepic-cuk circuit with the bipolar circuit using fuzzy control. The bipolar circuit in this simulation uses 2 pieces of PV with a power of 100 WP for every 1 piece of PV, where PV is arranged in parallel so as to produce an output voltage of 17.5 Volts and an output current of 11.44 Amperes. The complete circuit simulation can be seen in Figure 7.

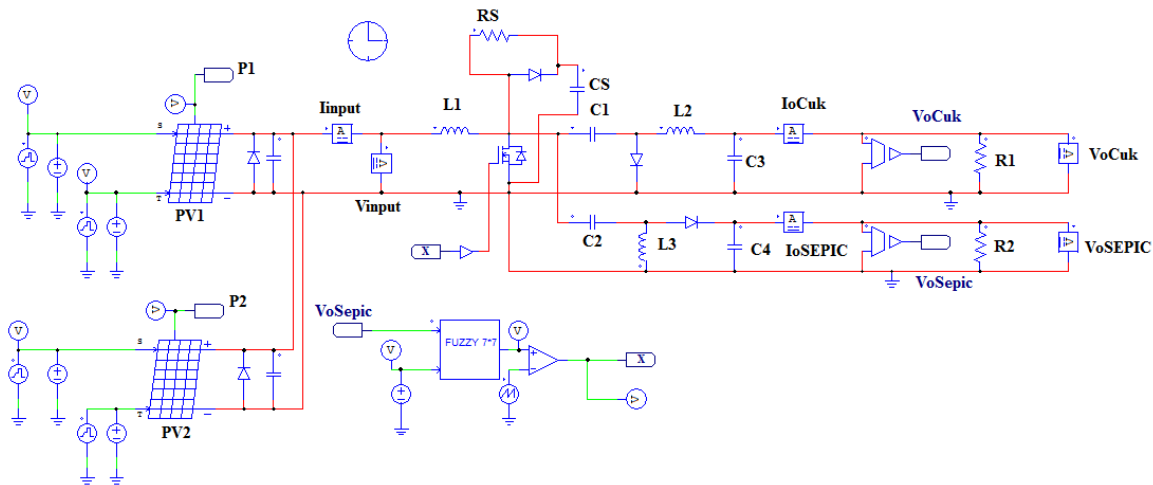

Figure 7. Sepic – Cuk Converter Circuit

The first simulation experiment was to try a bipolar sepic-cuk circuit without using controls. With a Duty Cycle value of 44.1%. The voltage output response when not using the control can be seen in Figure 8. Where the output voltage of the converter is not worth the setpoint of 13.8 Volts.

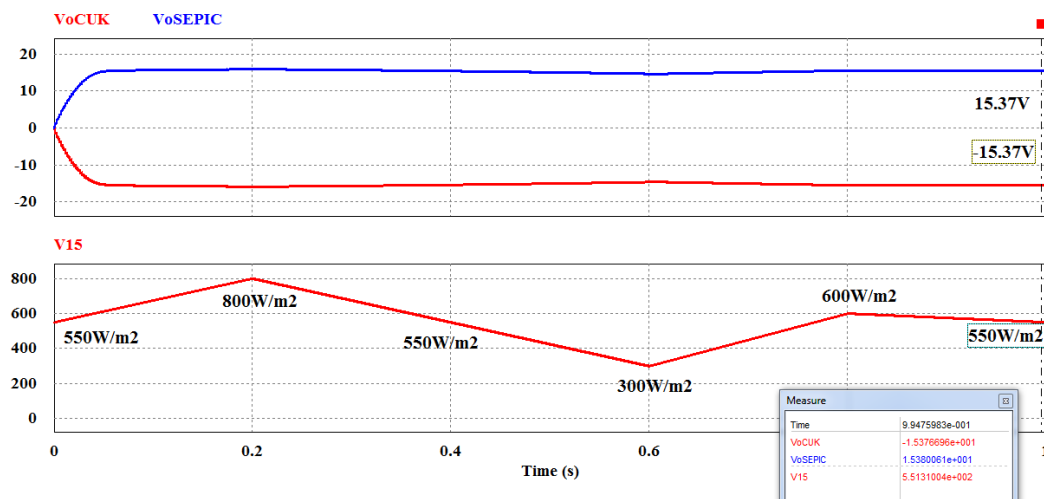

Figure 8. Voltage Output Response Without Control

In Figure 9 try the bipolar sepic-cuk circuit using controls when disturbed on the irradiance side. Condition 1 disturbance is given at seconds 0, 0.2, 0.4, 0.6, 0.8 and 1. Voltage output response when using control produces a stable voltage when disturbed.

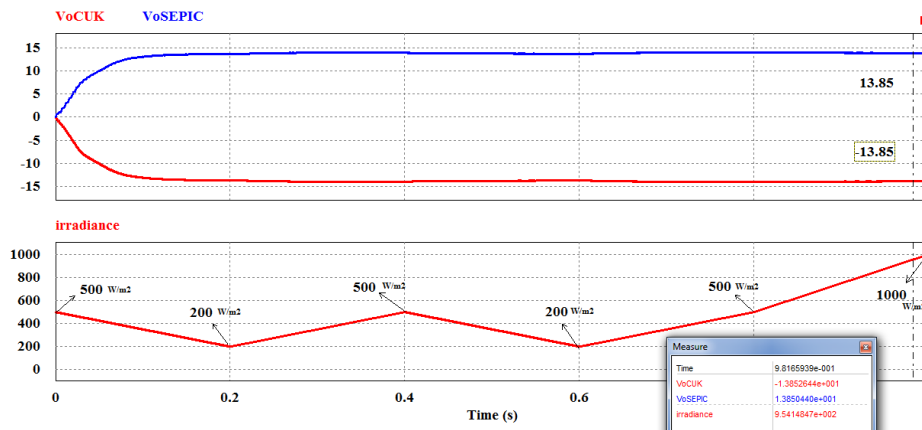

Figure 9. Output voltage response when disturbed on the irradiance side

In Figure 10, trying a bipolar sepic-cuk circuit uses controls when given an irradiance disturbance. The second fault condition is given in seconds 0, 0.2, 0.4, 0.6, 0.8 and 1. Voltage output response when using the control produces a stable voltage when disturbed

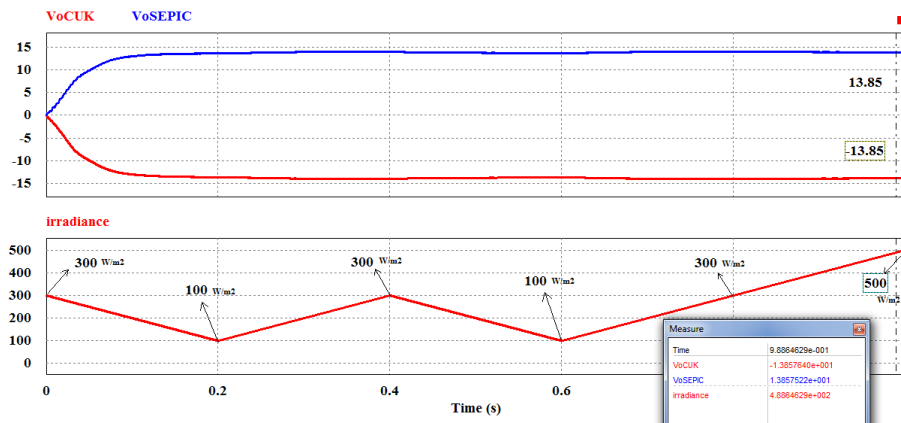

Figure 10. Output voltage response when disturbed on the irradiance side

In Figure 11, we try to control the bipolar sepic-cuk series using controls when disturbed on the irradiance side. The third condition is given at 0, 0.2, 0.4, 0.6, 0.8 and 1. The output voltage response when using the control produces a stable voltage when disturbed

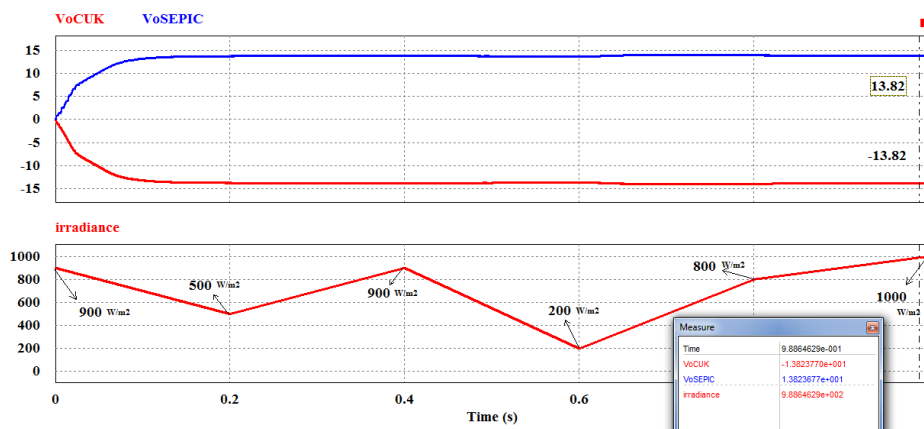

Figure 11. Output voltage response when disturbed on the irradiance side

In Figure 12, trying a bipolar sepic-cuk circuit uses controls when subjected to temperature disturbances. The condition of the 4 disturbances is given in seconds 0, 0.2, 0.4, 0.6, 0.8 and 1. The output voltage response when using the control produces a stable voltage when disturbed

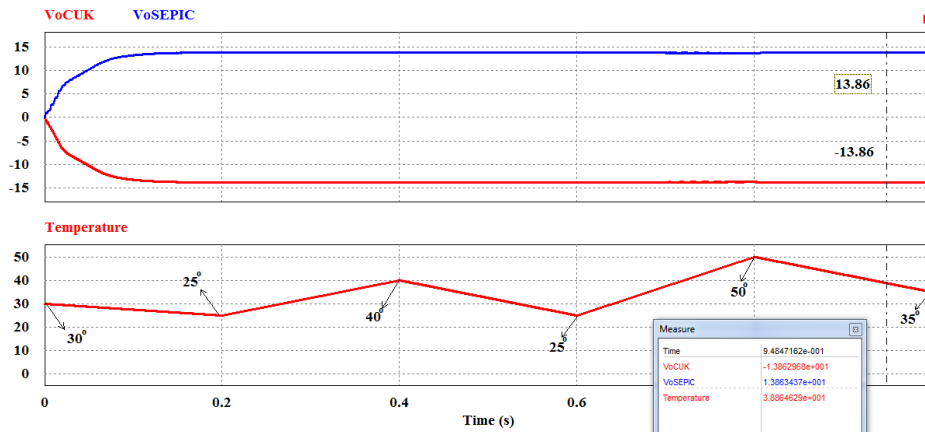

Figure 12. Output voltage response when given disturbance on the temperature side

In Figure 13, trying a bipolar sepic-cuk circuit uses controls when given a temperature disturbance. The fifth fault condition is given in seconds 0, 0.2, 0.4, 0.6, 0.8 and 1. Voltage output response when using control produces a stable voltage when disturbed

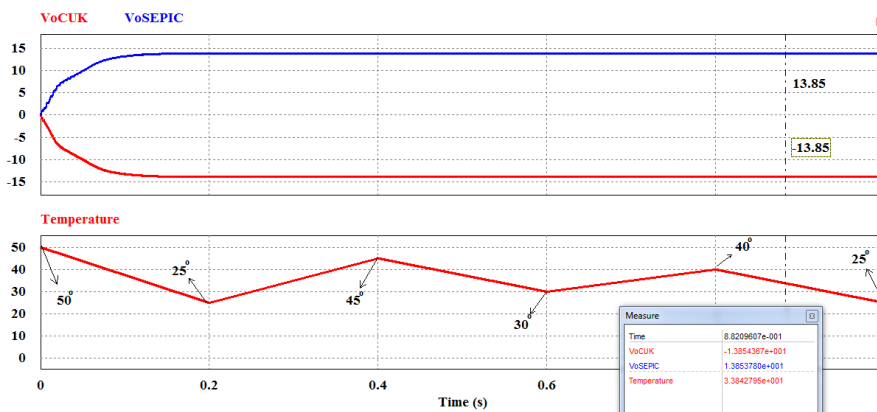

Figure 13. Output voltage response when given disturbance on the temperature side

In Figure 14, we try to control the bipolar sepic-cuk series using controls when disturbed at the temperature side. The sixth fault condition is given in seconds 0, 0.2, 0.4, 0.6, 0.8 and 1. Voltage output response when using control produces a stable voltage when disturbed.

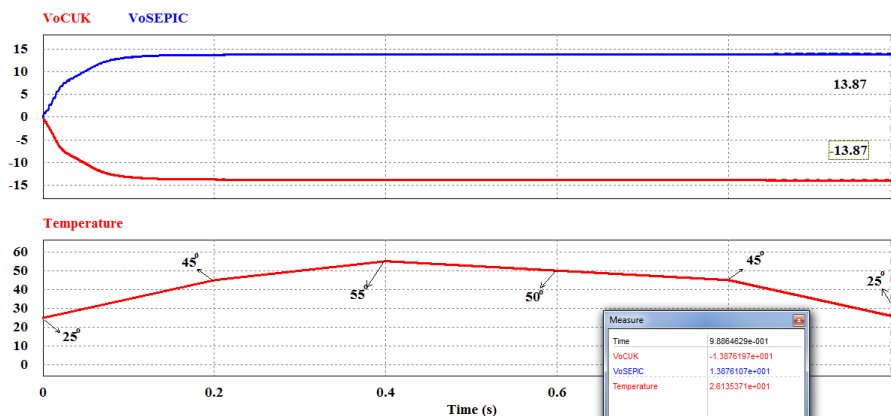

Figure 14. Output voltage response when given disturbance on the temperature side

In the next bipolar converter simulation by comparing fuzzy control and PI control. Figure 15 shows a bipolar converter circuit using PI control. PI values are obtained from the tuning process and running open-loop simulation. The bipolar circuit in this simulation uses 2 pieces of PV with a power of 100 WP for every 1 piece of PV, where PV is arranged in parallel so as to produce an output voltage of 17.5 Volts and an output current of 11.44 Amperes.

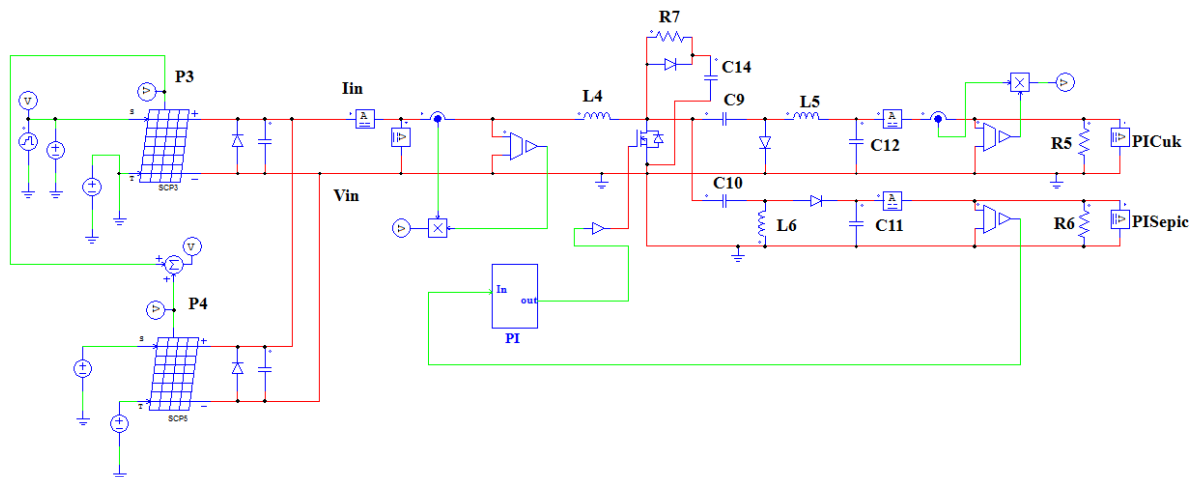

Figure 15. Sepic – Cuk Converter Circuit with PI Control

Figure 16 shows the output voltage response of the PI control. The results obtained after running the simulation are the Cuk output voltage is -13.85 Volt and the Sepic output voltage is 13.82 Volt. The error generated from the PI control simulation for the Cuk converter is 0.36% and the Sepic converter is 0.14%. It can be concluded that the time needed to reach the setpoint using the PI control for the SEPIC converter is 0.269 second and for the Cuk converter is 0.269 second while using fuzzy control the time needed to reach the setpoint for the SEPIC converter is 0.228 second and for the Cuk converter is 0.228 second.

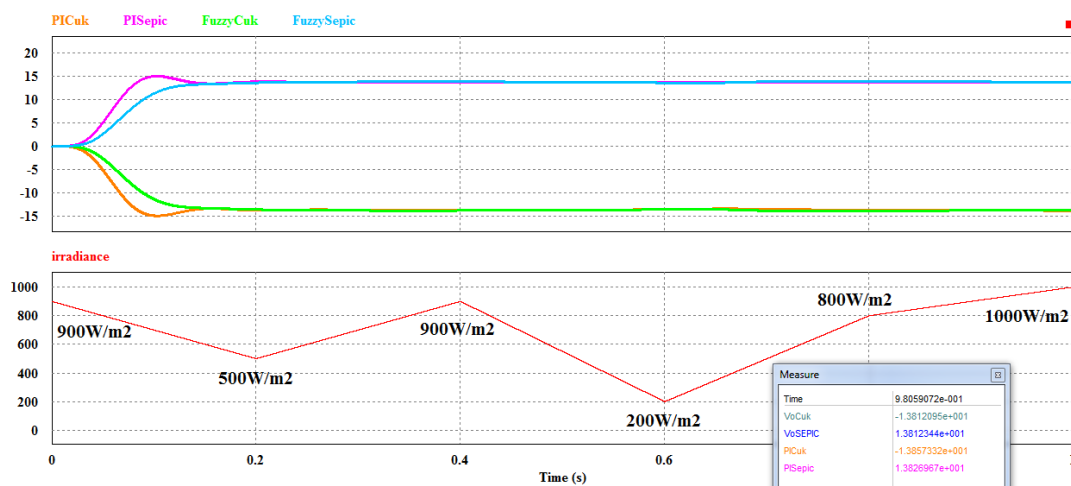

Figure 16. The Output voltage response of PI Control and Fuzzy Control

From Table 4 and Table 5 the Bipolar SEPIC-CUK converter simulation results are obtained using fuzzy control. Where the simulation is given interference on the Irradiance and Temperature side. With a Setpoint Voltage of 13.8 Volts, a change in condition from condition 1 to condition 6 shows that the range of error percentage output voltage is 0.14 - 0.5%.

Table 4. Simulation Results Using Fuzzy Control When Given Interference

irradiance change						
No	Condition	V Output SEPIC (V)	V Output CUK (V)	Setpoint (V)	% Error SEPIC	% Error CUK
1	1	13.85	-13.85	13.8	0.36	0.36
2	2	13.85	-13.85	13.8	0.36	0.36
3	3	13.82	-13.82	13.8	0.14	0.14

Table 5. Simulation Results Using Fuzzy Control When Given Interference

Temperature change						
No	Condition	V Output SEPIC (V)	V Output CUK (V)	Setpoint (V)	% Error SEPIC	% Error CUK
1	4	13.86	-13.86	13.8	0.43	0.43
2	5	13.85	-13.85	13.8	0.36	0.36
3	6	13.87	-13.87	13.8	0.5	0.5

5. Conclusion

The Bipolar SEPIC-CUK Converter system has been simulated. Simulation results show that the system can run well. The output voltage of the converter has been achieved with fuzzy control with irradiation and temperature variations. The results of the output voltage can be maintained at a predetermined voltage. Error percentage of the generated voltage is equal to 0.14 - 0.5%.

Acknowledgment

Thank you to the supervisor who has supported and guided the authors very well in the process of research preparation and to the Politeknik Elektronika Negeri Surabaya.

References

- [1] Shamil M, "A Hybrid DC-DC Converter for Bipolar Applications", IJEECS, 2017.
- [2] Sandhiya Rai, Maheswarlb, "Bipolar DC Microgrid Operation Using SEPIC and CUK Converter", ISSN, 2016.
- [3] M.B Ferrera, S.P Litrin, E.Duran, J.M Andujar, "A SEPIC-CUK Converter Combination for Bipolar DC Microgrid Applications", IEEE, 2015.
- [4] Devika.P.V, Rosemin Parackal, "SEPIC-CUK Converter for PV Application Using Maximum Power Point Tracking Method", ICCPCCT, 2018.
- [5] Jafar Marjani, Amir Imani, Arsalan Hekmati, E.Afjei, "A New Dual Output DC-DC Converter Based on SEPIC and CUK Converter", IEEE, 2016.
- [6] Manish Kumar, Ashirvad M, Narendra Babu Y, "An Integrated Boost-Sepic-Cuk DC-DC Converter with High Voltage Ratio and Reduced Input Current Ripple", PECCON, 2017.
- [7] Saptarshi Rakshit, Jayabrata Maity, "Fuzzy Logic Controlled CUK Converter", IEEE, 2018.
- [8] Rohit R. Deshmukh, Makarand S.Ballal, Girish G. Talapur, H.M Suryawanshi, "Distributed Control for Power Management Based on Fuzzy Logic in DC Microgrid, IEEE, 2018.
- [9] Saon Maity, Soham Ghosh, "Performance Analysis of Fuzzy Logic Controlled DC-DC Converters", IEEE, 2019.
- [10] Moh. Zaenal Efendi, Farid Dwi Murdianto, Rangga Eka Setiawan, "Modelling and Simulation of MPPT Sepic Converter Using Modified PSO to Overcome Partial Shading Impact on DC Microgrid System", IEEE, 2017.

- [11] Ainur Rofiq Nansur, Alfis Syah Laili Hermawan, Farid Dwi Murdianto, “Constant Voltage Using Fuzzy Logic Controller (FLC) to Overcome The Unstable Output Voltage of MPPT in DC Microgrid System”,IEEE,2018.
- [12] Moh. Zaenal Efendi, Suhariningsih, Farid Dwi Murdianto, Evi Inawati, “Implementation of Modified P&O Method as Power Optimizer of Solar Panel Under Partial Shading Condition for Battery Charging System”,AIP Conference, 2018.
- [13] J.Gonzalez Garza, B.Chong, L.Zhang,”Control of Integrated Cuk Converter and Photovoltaic Modules for Maximum Power Generation”, IEEE, 2012.
- [14] M.K.R.Noor, A. Ponmiran, M.A.Z.A Rashid,“Optimization Parameter Design of SEPIC-Cuk Converter”, International Journal Of Integrated Engineering, 2019.
- [15] John E. Salazar, Jesus Gonzalez, “A Fuzzy Logic Controller Based on Output Reference Tracking Applied to Photovoltaic Systems Using SEPIC Converter”,IEEE, 2016.
- [16] Soon Maity, Soham Ghosh, Rounak Pal, “Performance Analysis of Fuzzy Logic Controlled DC-DC Converter”, IEEE, 2019.
- [17] Anooja Shahul, Prof Annie P Oommen, Prof. Benny Cherian, “ Self Lifted SEPIC-Cuk Combination Converter”, Novelty Journal, 2016.
- [18] Bor-Ren Lin, Jyun-JI Chen, Kun-Liang Shih,”Analysis and Design of Soft-Switching SEPIC-Cuk Converter”, International Journal of Electronics, 2011.
- [19] Mriduwani Verma, S.Shiv Kumar,”Hardware Design of SEPIC Converter and its Analysis”, IEEE,2018.
- [20] Daniel W. Hart. 2011. Power Electronics. New York. The McGraw-Hill Companies.