



PAPER • OPEN ACCESS

Multi DC Load Single Port Output Adaptive Power Charge Using Fuzzy Logic Controller

To cite this article: A N Maulidyna *et al* 2021 *IOP Conf. Ser.: Mater. Sci. Eng.* **1096** 012063

View the [article online](#) for updates and enhancements.

You may also like

- [Electric Machines Virtual Laboratory: Testing of DC Motor](#)
R Badarudin, D Hariyanto, M Ali et al.
- [Influence of Direct Current Electric Field on Electrode Process of Carbon Steel under Thin Electrolyte Layers](#)
Yang Chen, Yan Yang, Junxi Zhang et al.
- [A COMPREHENSIVE, WIDE-FIELD STUDY OF PULSATING STARS IN THE CARINA DWARF SPHEROIDAL GALAXY](#)
A. Katherina Vivas and Mario Mateo

ECS The Electrochemical Society
Advancing solid state & electrochemical science & technology

247th ECS Meeting
Montréal, Canada
May 18-22, 2025
Palais des Congrès de Montréal

Abstracts due December 6th

Showcase your science!

Multi DC Load Single Port Output Adaptive Power Charge Using Fuzzy Logic Controller

A N Maulidyna¹, I Sudiharto², F D Murdianto³

^{1,2,3} Department of Electrical Engineering, Politeknik Elektronika Negeri Surabaya. Surabaya, East Java, Indonesia

Abstract. The battery is an electronic device that is capable of storing electrical energy. The ability of batteries to store electrical energy is widely used to supply DC loads. Batteries on a wide range of DC loads have varying voltages and capacities. Generally, battery chargers are likely to be static with one specific load voltage. One charge device is usually used to charge one type of DC load. The Adaptive power charge system can be used to charge various types of DC loads with different voltages and capacities through one output port. In this paper method of charging with constant voltage, to keep the output voltage from the SEPIC converter stable used fuzzy logic controller. In this research, the adaptive power charge system using a fuzzy logic controller can charge various types of DC loads with different voltages, has a 99.8% precision with an average error of less than 0.16% and the system reaches a steady-state at 0.4 seconds. Adaptive power charge makes it easy to charge various types of DC loads.

1. Introduction

In the times, technology also developed very rapidly. There are many electronic types of equipment used to help everyday life. Electronic equipment that is not separated from human life such as mobile phones, laptops, cameras, etc[1] Electronic equipment requires electrical energy to work. Energy sources of electronic equipment generally use a battery. The battery has the ability to store electrical energy, so it can be used to supply various types of DC loads. Batteries used by electronic equipment are rechargeable battery or batteries that can be recharged.

The type of battery that is widely used in electronic equipment is Li-Ion. Use of the Li-Ion battery type because the single Li-Ion cell voltage is the same as the 3 Ni-CD battery type cells, capable of accommodating more power, easier for maintenance, and more economical price. These factors make Li-Ion batteries widely used. [2].

The battery used continuously can reduce the energy stored on the battery, so that the electronic equipment can not work, it is required charging to keep the electronic equipment operating. In general, chargers for mobile phones, laptops, and cameras have different voltages and different chargers. To charge electronic devices need a different charger for each electronic device. Generally, current battery chargers tend to be static at one type of DC load with a certain capacity. So a different battery charger is needed for different types of DC loads. This is considered less effective because one battery charger can only be used to charge one type of DC load with a certain voltage and capacity [3].

From this problem, it takes a system that is able to recharge the battery capable of working adaptive on various types of DC loads with different voltages and capacities. So with one charge port capable of



charging various types of DC loads with different voltages and capacities. To perform the battery charging process, a load selection is required so that it can determine the charging voltage setpoint. In this system, the source of the DC bus is connected with the DC-DC converter. DC-DC converters are widely used in a variety of applications [4]. The DC-DC converter that is used in this research is a sepic converter. The converter sepic is derived from the buck-boost converter [5] capable of producing the voltage greater or less than the input voltage. Unlike the buck-boost that has a reversed output. Compared to other DC-DC converters, the sepic converter has a higher efficiency [6]. The widely used method for charging a battery is constant current and constant voltage. [7] The constant current method makes the charging process is faster, but this will reduce the battery lifetime. But, when using a constant voltage method with a small charge current takes a long time for the charging process, but the lifetime of the battery can last longer [8-11]. The method used in this research is constant voltage. The selection of constant voltage (CV) because it has a simple circuit and easy to control [3]. To keep the output voltage from the Sepic Converter constant, then used the Fuzzy Logic Controller (FLC). Fuzzy Logic Controller has high accuracy and can be used on nonlinear loads such as batteries [12]. In this research using 3 types of DC loads that have different voltages and capacities, are the mobile phone, camera, and laptop. Adaptive power charge battery system, the charging process will be more effective and efficient. Use an adaptive power charge system, the charging process with only one device capable of being used to charge more than 1 type of battery with different charging voltages. So that the charging process is more efficient

2. System Design

In this research, a charging system is capable of working in adaptive with a type of DC load that has different voltages and capacities. DC load used is a 5 volt mobile charging voltage, a camera with 8 volt charging voltage, and a laptop with a 19 volt charging voltage. In Figure. 1 is an adaptive design of the battery rechargeable system.

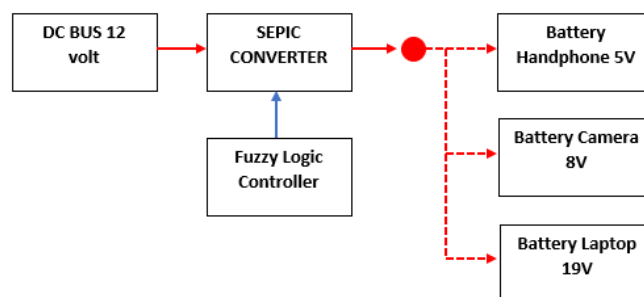

Figure 1. Overall system

In Figure. 1 is the design of an adaptive power charge system with a voltage input is 12 volt from the DC bus as a source. The voltage from the DC bus will pass through the converter sepic. Sepic Converter capable of producing the voltage greater or less than the input voltage for supply charging DC load which is connected in the system. Selection of load connected to the system based on the value of the next voltage and current as a reference setpoint determination. The Setpoint used is 5 volt for charging handphone, 8 volts for charging camera, and 19 volts for charging a laptop. The method for charging the battery is used as a constant voltage, to keep the output voltage of the converter sepic stable, according to the set point then used the Fuzzy Logic Controller (FLC).

3. System Modelling

3.1. Modelling of lithium-ion battery

The type of battery that is commonly used in electronic devices is Rechargeable Battery. When the battery is connected to the load then the battery works discharge, the existing electrons flow from the

negative to the positive. When the battery is recharged where the battery is connected to the outside source for charging. In the process of charging the electrons will flow from the positive pole to the negative pole so that the battery is charged. The battery used in this system is a type of Li-Ion (Lithium-Ion).

Battery modeling covers the charging process based on the State Of Charge (SOC) battery. This battery modeling uses Thevenin's equivalent circuit based on the battery's resistive and capacitive properties. [13]

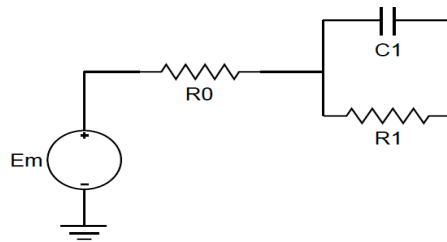

Figure 2. The equivalent circuit of Li-Ion battery

Figure 2. Shows the equivalent circuit of Li-Ion batteries using resistors and capacitors. The equation of the battery modeling in Figure 2 is as follows:

$$E_m = R_0 i_t + R_1 i_t \tag{1}$$

$$i_t = i_{ct} + i_{rt} \tag{2}$$

$$\frac{i_{ct}}{C_1} = R_1 \frac{di_{rt}}{dt} \tag{3}$$

3.2. Modelling of sepic converter

Single-Ended Primary Inductance Converter (SEPIC) is a DC-DC converter with a derivative topology of buck-Boost Converter[6]. Both the Sepic converter and buck-boost converter are capable of generating a larger or smaller output voltage than the input voltage. However the buck-boost converter has the polarity is the reversal, while the converter sepic without changing the polarity of the output [7].

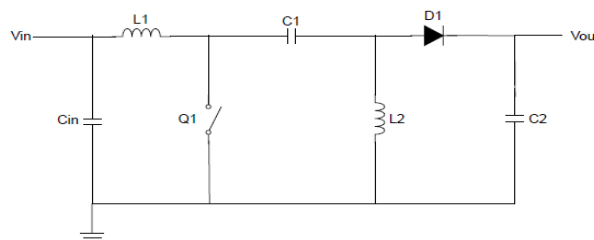

Figure 3. Sepic converter circuit

In Figure 3. Is a sepic converter circuit. Sepic converter has two conditions, the first condition when the switch close and the second condition when the switch is open. The sepic converter consists of an electronic switch such as MOSFET, a diode, two inductors L1 and L2, and two capacitors of C1 and C2 [14].

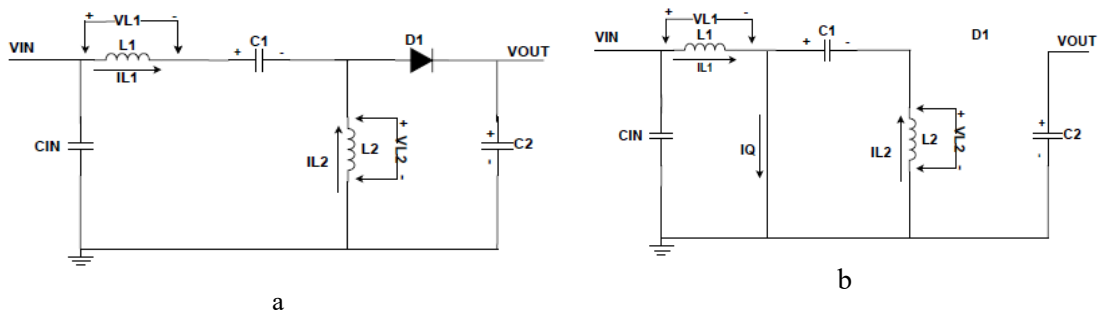

Figure 4. Topology sepic Converter when switch off (a),when switch on (b)

Table 1 is a specification of the SEPIC Converter design used in this research

Parameters	Symbol	Value	Units
Input voltage	VIN	12	Volt
Output voltage	VOUT	19	Volt
Ripple current	ΔIL	1.354	A
Ripple voltage	$\Delta VRPL$	0.019	Volt
Frequency switching	fs	40	kHz
Inductor 1	L1	135	uH
Inductor 2	L2	135	uH
Capasitor 1	C1	2.747	uF
Capasitor 2	C2	2.747	uF
Resistor	R	5.5	ohm

3.3. Fuzzy logic Controller

The fuzzy logic is the logic of thinking with unclear facts [8]. This fuzzy theory is introduced by Lotfi Zadeh based on the way people perceive an uncertain value. the fuzzy logic controller has several parts of the system such as Figure. 5.



Figure 5. The basic structure of the fuzzy logic controller system

Fuzzification is a process of changing the input from a strict form (crisp) to fuzzy (linguistic variable) presented in the form of a fuzzy set with a membership function respectively. In the fuzzification process, there are 2 inputs, error (e (k)) and delta error (de (k)). the error value is obtained from the difference in value between the reference voltage and the measurement results. In the vreff system is the reference voltage and vo is the output voltage [15]. the equation can be written down.

$$e(k) = v_{reff} - v_o \tag{9}$$

while changing the voltage error value can be written:

$$de(k) = e(k) - e(k-1) \tag{10}$$

The membership function used in fuzzification is shown in Figure 6. In this research, the membership function consists of 5 triangles and 2 trapezoids. Use of 7 membership functions for more precise results

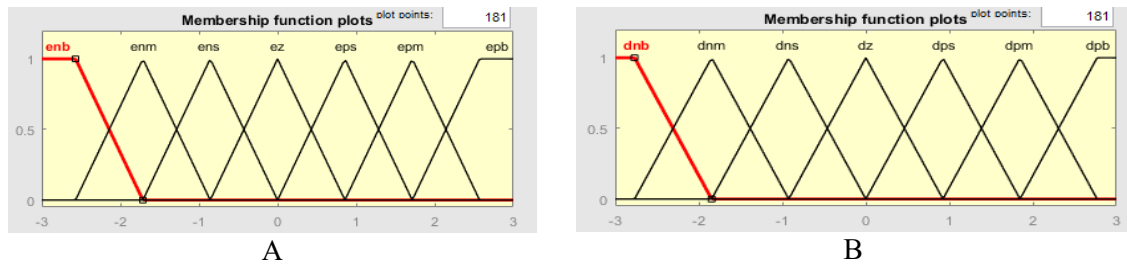

Figure 6. Fuzzy error input (a), fuzzy error delta input (b)

The fuzzy rule base contains IF-THEN statements. Determination of the rule base is done after fuzzification consists of a set of rules based on fuzzy logic to declare a condition. Determination of the rule base affects the precision of the model, at the decision-making stage it is determined based on the rule base. Table 2 shows the rule base design used in this research.

Table 2. Rule table of fuzzy logic controller

<i>e/de</i>	NB	NM	NS	ZO	PS	PM	PB
NB	NB	NB	NB	NB	NM	NS	ZO
NM	NB	NB	NM	NM	NS	ZO	PS
NS	NB	NM	NS	NS	ZO	PS	PM
ZO	NB	NM	NS	ZO	PS	PM	PB
PS	NM	NS	ZO	PS	PS	PM	PB
PM	NS	ZO	PS	PM	PM	PB	PB
PB	ZO	PS	PM	PB	PB	PB	PB

The Output of the rule base is still a fuzzy value, so the defuzzification is required to change the fuzzy value (linguistic variable) to a strict value that will then be sent to the system/plant. In Figure. 7 output fuzzy and surface view of the fuzzy logic controller

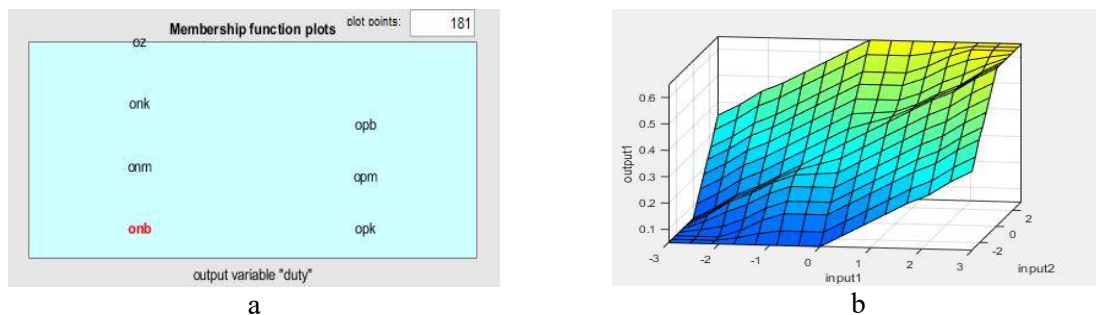

Figure 7. Fuzzy output (a), fuzzy surface (b)

Figure 7 (a) is the output membership function of the designed fuzzy logic controller. In the output, there are 7 membership functions with type constant. Figure 7 (b) shows the surface view of the fuzzy logic controller design.

4. Experiment result

4.1. Simulation system

In this research, the adaptive power charge is simulated for PSIM software. In this simulation, an adaptive power charge system made with 12 Volt input voltage of DC bus and connected to a Sepic converter. Using different DC loads with one output pot with setpoint output voltage is 5 Volt, 8 Volt, and 19 Volt.

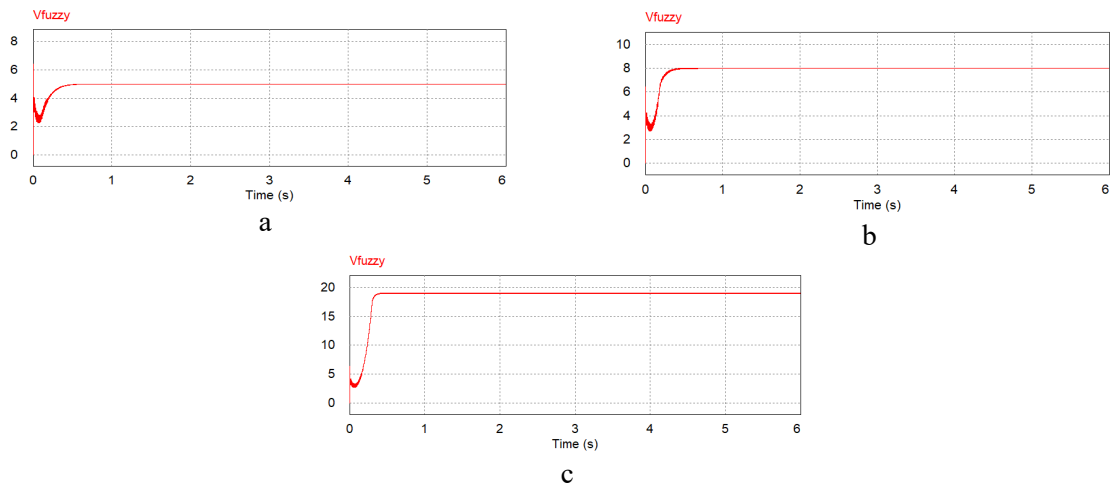

Figure 8. System response using FLC (a) setpoint 5 volt for handphone, (b) setpoint 8 volt for camera, (c) setpoint 19 volt for laptop.

In Figure. 8, the output voltage of the sepic converter with 3 different loads and different set points is controlled using a Fuzzy Logic controller. The loads used are cellphones with a set point of 5 volts, a camera with a set point of 8 volts, and a laptop with a set point of 19 volts. In this research, the system with the fuzzy logic controller has no overshoot and the time to reach the set point ranges from 0.4 seconds.

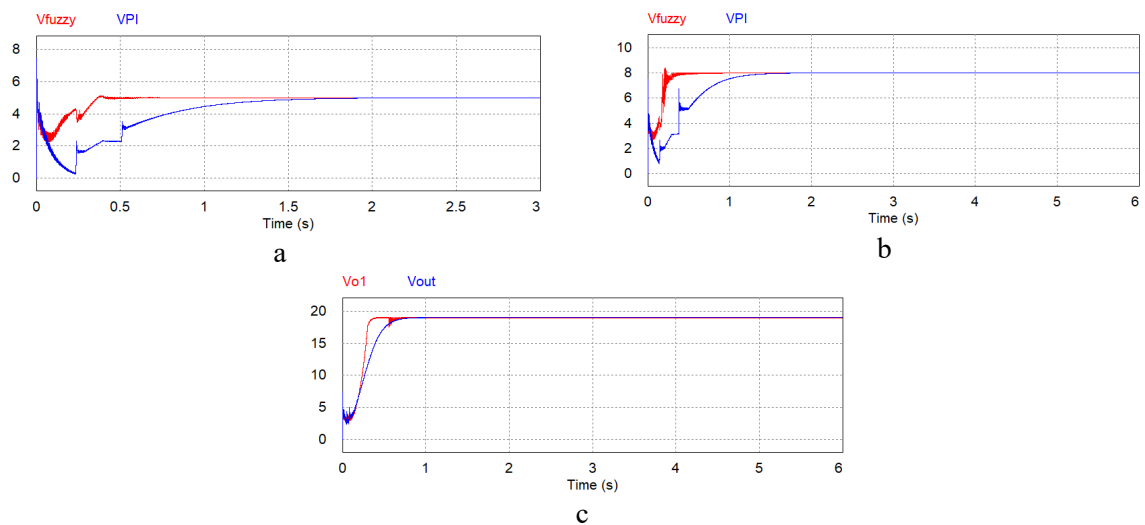

Figure. 9. Comparison of PI and Fuzzy setpoint 5 volts for charging handphone (a), setpoint 8 volts for charging camera (b), setpoint 19 volts for charging laptop (c).

In Figure.9. Shows comparisons between PI controls and fuzzy controls. The use of fuzzy controls has a faster time reaching a set point that ranges from 0.4 seconds, unlike PI controls that take longer to reach a set of points ranging from 1 to 1.6 seconds. PI control needs calculation at each set point for the value of K_P and K_I . while the fuzzy logic controller can work adaptively with changing loads and changing setpoint settings

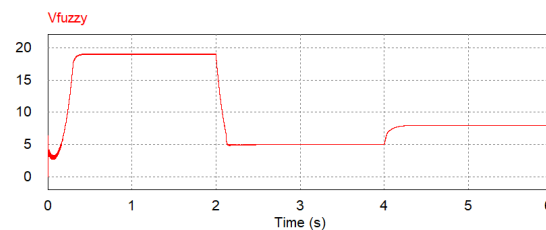

Figure 10. Responses system with fuzzy controls uses 3 different setpoints

In Figure.10 shows the change in the voltage value with the load changing. the output voltage value of 19 volts for charging laptop, 5 volt for charging handphone, and 8 volts for charging battery camera. In the result of the response, the system can work with adaptive with different loads and set points

Table 2. Comparison result system between using the fuzzy logic controller and PI controller

No	Vin (Volt)	Set point (Volt)	Vout Fuzzy (Volt)	Vout PI (Volt)	Current (Amper)	Error fuzzy (%)	Error PI (%)
1	12	5	4.99	4.97	0.89	0.2	0.6
2	12	8	7.99	7.92	1.42	0.125	1
3	12	19	18.97	18.9	3.3	0.157	0.526

Table 2 shows a comparison of the use of fuzzy control and PI control in the adaptive power charge system. The fuzzy logic controller has an average error value of less than 0.167%, with details when the cellphone is connected, the setpoint is 5 volts, the output voltage is 4.99 volts when the camera battery is connected, the setpoint is 8 volts, the output voltage is 7.99 volts, and when the laptop is connected the setpoint is 19 volts, the output voltage 19 volts. PI control has an average error of 0.7%. PI control needs different calculations for each value of KP KI so it needs 3 calculations for 3 setpoints, PI control cannot work adaptively to the specified setpoint. In contrast to the fuzzy logic controller, it is able to work to adaptively the output voltage to a specified set point.

5. Conclusion

In this research, the Multi DC Load Single Port Output Adaptive Power Charge System Using Fuzzy Logic Controller is able to work adaptively according to the charging voltage at the connected load. The fuzzy logic controller works adaptively to adjust the output voltage of the sepic converter according to the connected load set point. PI controller needs different calculations for each value of KP KI so it needs 3 calculations for 3 setpoints, PI control cannot work adaptively to the specified setpoint. The results of experiments for the charging process using FLC have been simulated and compared with PI controls. FLC has a faster response than PI control, it takes 0.4 seconds to reach the steady-state with a precision reaching 99.8% and an average error of 0.16% smaller than the PI control that is 0.708%. The adaptive power charge system using a fuzzy logic controller makes it easier to charge various types of loads with one device.

References

- [1] Houshyar Asadi, S.Hr..Aghay Kaboli, Arash Mohammad, Maysam Oladazini (2011) Fuzzy Control Based Five-Step Li-Ion Charger by Using AC Impedance Technique (Malaysia: University of Malaya) SPIE
- [2] Ming-Wang Cheng, Shih-Ming Wang, Yuang-Shung Lee, Sung-Hsin Hsiao (2009) Fuzzy Controlled Fast Charging System for Lithium-Ion Batteries (Taiwan) PEDS2009
- [3] Indhana Sudiharto, Farid Dwi Murdianto, Irianto, Ayu Wulandari, (2019) Adaptive Power Charge using PID Controller on DC Load Application
- [4] Reza Moradpour, Hossein Ardi, and Abdolreza 2018 Design and Implementation of a New

- SEPIC-Based High Step-Up DC/DC Converter for Renewable Energy Applications (Tavakoli) IEEE Transactions On Industrial Electronics, Vol. 65, No. 2
- [5] P. U. Rani and S. Saravanan 2017 Simulation and modeling Of SEPIC converter with high static gain for renewable application Asian Conference on Energy, Power and Transportation Electrification (ACEPT).
- [6] Mriduwani Verma and S. Shiv Kumar 2018 Hardware Design of SEPIC Converter and its Analysis (India) IEEE.
- [7] Ma dandan, Bai jing, You fahai 2011 Study on Transition Charging Method of lithium-ion battery Based on the multiple model adaptive Control ((China) pp 19-22.
- [8] W.F. Bentley and D.K. Heacock 1996 Battery Management Consideration for Multichemistry System IEEE Aerospace and Electronic System Magazine, vol. 11, no. 11, pp. 23-26.
- [9] V.L. Teofilo, V.L. Mermitt and R. P. Hollandsworth 1997 Advanced Lithium Ion Battery Charge, vol. 12, no. 11, pp. 227-231, 1997.
- [10] W.F. Bentley 1997 Cell Balancing Considerations for Lithium Ion Battery System Battery Conference on Applications and Advances, pp. 223-226
- [11] J.A. Martin, M. Gonzalez, M.A. Perez, F.J. Ferrero and J. Diaz 1998 A Microcontroller-Based Intelligent Fast Charge for Ni-Cd and Ni-MH Batteries in Portable Application IEEE Industrial Electronic Conference (IECON'98), vol. 3, pp. 1638-1643
- [12] Jerzy Bakalarczyk 2017 Charging of PV Battery At Constant Current Mode By Using Fuzzy Logic Control (Poland) pp 85-229.
- [13] Zhai Haizhou 2017 Modeling of Lithium-ion Battery for Charging/Discharging Characteristics Based on Circuit Model (China : Heze University)
- [14] Daniel W. Hart. 2011. Power Electronics. New York. The McGraw-Hill Companies.
- [15] Cetin Elmas, Omer Deperlioglu, Hasan Huseyin Sayan 2009 Adaptive fuzzy logic controller for DC-DC converters (Turkey : University of Gazi) pp 1540-1548.
- [16] Sounyadeep Nag, Kwang. Y. Lee 2019 Optimized Fuzzy Logic Controller for Responsive Charging of Electric Vehicles (USA : Baylor University) pp 147-152.
- [17] Zhifu Wang, Yupu Wang, Yinan Rong, Zhi Li, Lin Fantao 2015 Study On The Optimal Charging Method for Lithium-Ion Batteries Used In Electric Vehicles (China) pp 1013-1017.
- [18] Sana Mouslim, M'hand Oubella, Mustapha Kourchi, Mohamed Ajaamoum 2020 Simulation and analyses of SEPIC converter using linear PID and fuzzy logic controller (Morocco : Ibnzohr University)